

Hylid Frog Phylogeny and Sampling Strategies for Speciose Clades

JOHN J. WIENS,¹ JAMES W. FETZNER, JR.,² CHRISTOPHER L. PARKINSON,³ AND TOD W. REEDER,⁴

¹Department of Ecology and Evolution, Stony Brook University, Stony Brook, New York 11794-5245, USA; E-mail: wiensj@life.bio.sunysb.edu

²Section of Invertebrate Zoology, Carnegie Museum of Natural History, Pittsburgh, Pennsylvania 15213-4080, USA

³Department of Biology, University of Central Florida, Orlando, Florida 32816, USA

⁴Department of Biology, San Diego State University, San Diego, California 92182-4614, USA

Abstract.—How should characters and taxa be sampled to resolve efficiently the phylogeny of ancient and highly speciose groups? We addressed this question empirically in the treefrog family Hylidae, which contains >800 species and may be nonmonophyletic with respect to other anuran families. We sampled 81 species (54 hylids and 27 outgroups) for two mitochondrial genes (12S, ND1), two nuclear genes (POMC, *c-myc*), and morphology (144 characters) in an attempt to resolve higher-level relationships. We then added 117 taxa to the combined data set, many of which were sampled for only one gene (12S). Despite the relative incompleteness of the majority of taxa, the resulting trees placed all taxa in the expected higher-level clades with strong support, despite some taxa being >90% incomplete. Furthermore, we found no relationship between the completeness of a taxon and the support (parsimony bootstrap or Bayesian posterior probabilities) for its localized placement on the tree. Separate analysis of the data set with the most taxa (12S) gives a somewhat problematic estimate of higher-level relationships, suggesting that data sets scored only for some taxa (ND1, nuclear genes, morphology) are important in determining the outcome of the combined analysis. The results show that hemiphractine hylids are not closely related to other hylids and should be recognized as a distinct family. They also show that the speciose genus *Hyla* is polyphyletic, but that its species can be arranged into three monophyletic genera. A new classification of hylid frogs is proposed. Several potentially misleading signals in the morphological data are discussed. [Amphibians; anurans; combined analysis; hylid frogs; missing data; taxon sampling.]

What is the best sampling strategy to resolve the phylogeny of speciose clades? In the recent literature on phylogenetic theory, there has been extensive discussion and debate of the relative merits of sampling taxa versus sampling characters. For example, some authors have emphasized sampling more taxa (e.g., Hillis, 1996, 1998; Graybeal, 1998; Poe, 1998; Rannala et al., 1998; Wiens, 1998a; Zwickl and Hillis, 2002; Hillis et al., 2003) whereas others have emphasized sampling more characters rather than taxa (e.g., Kim, 1996, 1998; Poe and Swofford, 1999; Rosenberg and Kumar, 2001, 2003). This discussion has led to many useful insights. However, simulations (and other studies) typically have made two important assumptions: (1) all characters in the analysis are evolving at a similar rate (or the same distribution of rates), and (2) all the taxa in the analysis are sampled for the same characters. In this article, we explore sampling strategies that depart from these assumptions, using hylid frogs as an empirical example.

Many phylogenetic studies of speciose clades can be classified as either “top down” or “bottom up” in their approach, based on their overall sampling design with regard to number of taxa, number of characters, and the evolutionary rate(s) of the sampled characters (Fig. 1). The bottom-up approach focuses on resolving only higher-level relationships (i.e., the base or bottom of the tree), often using a limited number of taxa, large numbers of characters, and at least some relatively slow-evolving markers (e.g., single-copy nuclear genes; Murphy et al., 2001; Takezaki et al., 2004; Hoegg et al., 2004). In contrast, the “top-down” approach involves more extensive species-level sampling (i.e., addressing the “top” of the tree as well as the base), often with a smaller number of characters per taxon and characters that are

evolving rapidly enough to resolve species-level relationships (e.g., mitochondrial DNA sequences in animals; Macey et al., 2000; Darst and Cannatella, 2004). Both approaches risk the misleading effects of long-branch attraction (Felsenstein, 1978; Hendy and Penny, 1989), but use of slow-evolving markers may reduce this danger for the bottom-up approach, whereas inclusion of many taxa may help subdivide long branches for the top-down approach (e.g., Hendy and Penny, 1989; Hillis, 1998).

In some ways, neither of these two extreme approaches is entirely satisfactory. The bottom-up approach can potentially resolve relationships among well-established clades. However, if the ingroup species have not already been sorted into major clades, the phylogenetic conclusions may have to be restricted to the limited number of species that are included. In contrast, the top-down approach may assign large numbers of species to major clades, but has a potential disadvantage in that character sets that are optimal for resolving species-level relationships may not be optimal for reconstructing higher-level relationships (i.e., they may be evolving too quickly or be insufficient in number).

Of course, systematists are not confined to using only one approach or the other, and many intermediate or combined strategies are possible and may be widely used. For example, one can first apply the bottom-up approach to resolve relationships among major clades and then apply the top-down approach to separate analyses within each major clade. However, the success of this second step may depend upon knowing which species belong to which major clades. Unfortunately, the bottom-up approach tells us relatively little about the content of these clades, because only a limited sample of species are included. Thus, one could apply the bottom-up approach

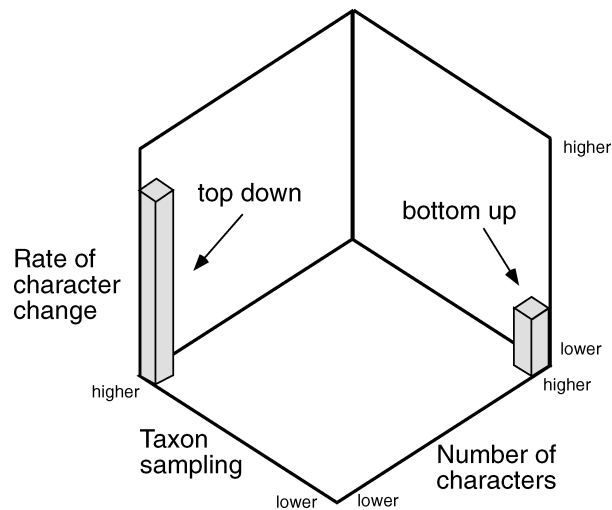

FIGURE 1. The sampling design of phylogenetic studies should consider a parameter space of at least three critical variables: number of taxa, number of characters, and the rate of change of those characters. Many empirical studies take a “bottom-up” approach towards resolving the higher-level phylogeny of a group, focusing on sampling fewer taxa and many characters, often with an emphasis on slowly evolving characters. Other studies take a “top-down” approach, sampling many taxa for a smaller number of characters, which may be more rapidly evolving. Two examples are illustrated here, but empirical studies might fall anywhere in this parameter space. For example, some studies may take a bottom-up approach but focus on relatively fast-evolving characters, such as analyses of animal phylogeny based on comparison of whole mitochondrial genomes.

to address relationships among families (i.e., using a limited number of exemplars from each) and then apply the top-down approach within each family, but this two-step process could be problematic if the families are not monophyletic.

Ideally, we would resolve higher-level and species-level relationships simultaneously, without having to sample every species for every character. One way that this might be accomplished is to implement both of these extreme sampling strategies and then combine the two data sets in a single analysis. In theory, this combined approach could simultaneously resolve higher-level relationships with slow-evolving markers scored for a limited number of taxa and resolve species-level relationships using fast-evolving markers scored for many taxa, without making a priori assumptions about which species belonged to which higher-level clades.

An obvious problem in such a combined approach is that the resulting matrix would likely be dominated by missing data cells. The majority of taxa would be scored only for the small number of (fast-evolving) characters and would lack data for the majority of characters (including the slow-evolving ones), leading to a highly incomplete matrix. But to what extent are these missing data really problematic? Recent simulations (Wiens, 2003; Phillipe et al., 2004) suggest that highly incomplete taxa can be included and accurately placed in phylogenetic analyses regardless of how many missing data cells they bear. In general, the critical parameter is the number

of characters for which they have data, not the amount or proportion of data that they lack. Thus, it should be possible to do a combined analysis in which the relationships among major clades are resolved by the large set of slow-evolving characters in the exemplar taxa, and the species that belong to those major clades are determined based on limited data from more fast-evolving characters. Although this sounds plausible, such an approach needs to be explored with empirical data.

Hylid Frogs

Hylid frogs are the second largest family of amphibians (exceeded only by leptodactylid frogs) with at least 861 species in 42 genera currently recognized (Table 1; AmphibiaWeb, 2004). Hylids are known colloquially as treefrogs. Most species are arboreal, and the family is characterized by several traits that presumably represent adaptations to arboreal habitat use (e.g., expanded toe pads, intercalary phalangeal elements). Hylids are most diverse in the New World tropics, but also include many Australian species (subfamily Pelodyrinae) and are also represented in North America, Europe, North Africa, the Middle East, and Asia (Duellman, 2001).

In many ways, hylids pose a particularly challenging phylogenetic problem. There have been no detailed phylogenetic analyses of the family (e.g., addressing relationships among all or most genera). A morphological study (Duellman, 2001; based in part on an unpublished dissertation by da Silva, 1998) of subfamilial relationships weakly supported the monophyly of the family but showed no evidence for the monophyly of the subfamily

TABLE 1. Current classification of the anuran family Hylidae, showing the number of currently described species in each genus/number represented in our analysis. Numbers were taken from AmphibiaWeb on 30 August 2004.

Phyllomedusinae (6/4 genera; 50/14 sp.)	<i>Hyla</i> (337/86)
<i>Agalychnis</i> (8/4)	<i>Lysapsus</i> (3/1)
<i>Hylomantis</i> (2/0)	<i>Nyctimantis</i> (1/0)
<i>Pachymedusa</i> (1/1)	<i>Osteocephalus</i> (18/3)
<i>Phasmahyla</i> (4/0)	<i>Osteopilus</i> (3/2)
<i>Phrynomedusa</i> (5/1)	<i>Phyllodytes</i> (10/1)
<i>Phyllomedusa</i> (30/8)	<i>Phrynohyas</i> (7/1)
Hemiphractinae (5/5 genera; 80/7 sp.)	<i>Pseudacris</i> (14/14)
<i>Cryptobatrachus</i> (3/1)	<i>Pseudis</i> (6/1)
<i>Gastrotheca</i> (48/3)	<i>Pternohyla</i> (2/1)
<i>Hemiphractus</i> (6/1)	<i>Ptychohyla</i> (12/3)
<i>Flectonotus</i> (5/1)	<i>Scarthyla</i> (1/1)
<i>Stefania</i> (18/1)	<i>Scinax</i> (85/6)
Hylinae (28/21 genera; 568/137 sp.)	<i>Smilisca</i> (6/3)
<i>Acris</i> (2/2)	<i>Sphaenorhynchus</i> (11/1)
<i>Anothea</i> (1/1)	<i>Tepuihyla</i> (8/0)
<i>Aparasphenodon</i> (3/0)	<i>Tripurion</i> (2/1)
<i>Aplastodiscus</i> (2/0)	<i>Trachycephalus</i> (3/1)
<i>Argenteohyla</i> (1/0)	<i>Xenohyla</i> (2/0)
<i>Calypthahyla</i> (1/1)	Pelodyrinae (3/3 genera; 163/11 sp.)
<i>Corythomantis</i> (1/0)	<i>Cyclorana</i> (13/3)
<i>Duellmanohyla</i> (8/2)	<i>Litoria</i> (126/5)
	<i>Nyctimystes</i> (24/4)

Hylinae, which contains the majority of the genera and species (Table 1). Molecular studies thus far have been based on relatively rapidly evolving markers (mitochondrial DNA) for a limited sampling of hylid species (e.g., Chek et al., 2001; Darst and Cannatella, 2004; Moriarty and Cannatella, 2004; Faivovich et al., 2004). Although there have been several noteworthy points of congruence between the molecular results and morphology-based taxonomy (e.g., monophyly of phyllomedusines and pelodyadines; Darst and Cannatella, 2004), these studies have not supported the monophyly of Hylidae. Specifically, the most extensive of these studies (16 genera, 26 species; Darst and Cannatella, 2004) suggested that the subfamily Hemiphractinae was more closely related to some leptodactylids than other hylids, and that the hemiphractines were themselves nonmonophyletic with respect to leptodactylids. Furthermore, morphological hypotheses (da Silva, 1998) and taxonomically limited molecular results (e.g., Faivovich et al., 2004) suggest that the speciose genus *Hyla* is not monophyletic. Given the potential nonmonophyly of the family Hylidae, subfamily Hylinae, and the speciose genus *Hyla*, resolving even the monophyly of hylid frogs may require an analysis that spans relationships among anuran families to species-level relationships within *Hyla*.

Goals of Study

In this study, we address the phylogenetic relationships of hylid frogs using morphological and molecular data, including 144 morphological characters, two mitochondrial genes, and two nuclear genes. We also address the problem of analyzing highly speciose and poorly known groups (i.e., those that require analysis of both higher level and species-level relationships). In an attempt to address the monophyly of hylids and their higher-level relationships, we first analyzed a set of 81 species sampled for all or most of the molecular and non-molecular characters, including slow-evolving nuclear genes (bottom-up strategy). This sampling of species included 54 hylid species and 27 representatives from other anuran families. In order to address assignment of species to major clades and lower-level relationships, we included an additional 115 species of hylids, primarily using data from a faster-evolving mitochondrial gene (from both our own data and from other studies).

We address several general questions relating to this combined sampling strategy. (1) Can the placement of highly incomplete taxa be resolved in the combined analyses? Given recent simulations, we predict that the placement of highly incomplete taxa can be well resolved (i.e., not placed in a polytomy), consistent with other lines of evidence (e.g., previous taxonomy), and strongly supported, or at least as strongly supported as taxa based on complete data (on average). (2) Are results from the analysis of all taxa using fast-evolving characters (12S) alone (i.e., the top down approach) consistent with those from the combined analyses including all taxa and characters? This question is especially critical; if the results of the two analyses are very similar, this outcome might support the

use of the fast-evolving characters alone (suggesting that the strategy of sampling slow-evolving characters for a limited set of taxa is not as useful). Furthermore, there is reason to question whether adding sets of characters scored for a limited number of taxa can positively influence the results of the combined analysis (in this case, the data from ND1, nuclear genes, and morphology). However, simulations suggest that adding characters scored for only some taxa can potentially be helpful, despite the missing data in these characters (Wiens, 1998b). (3) Do these conclusions depend upon which phylogenetic method is used? For example, are the results similar using both parsimony and model-based methods (e.g., Bayesian analysis)?

MATERIALS AND METHODS

Overall Sampling Strategy

For the complete data set (all characters) we sampled 54 species of hylids and 27 representatives of other anuran families. The 54 hylid species were chosen to represent the majority of hylid genera (31 of 42), and almost all genera for which we had adequate material for morphological and molecular analysis. Most of the 11 genera that we did not include are relatively depauperate, representing only 29 species total. Furthermore, we included multiple species for speciose genera (i.e., *Gastrotheca*, *Hyla*, *Osteocephalus*, *Pseudacris*, *Scinax*). For *Hyla*, we included representatives from throughout the geographic range of the genus and from putative major clades, including the 30-chromosome *Hyla* (Duellman and Trueb, 1983), the gladiator frogs and their relatives (da Silva, 1998; Duellman, 2001), and a clade including the Middle American, Nearctic, and Palearctic *Hyla* species (Duellman, 2001). There has been some support for the monophyly of some of these groups in previous molecular studies (e.g., Darst and Cannatella, 2004; Faivovich et al., 2004).

Choosing outgroup taxa necessitated consideration of higher-level frog phylogeny. Most species of frogs are thought to form a monophyletic group (Neobatrachia), which contains Hyloidea (formerly Bufonoidea) and Ranoidea (Duellman, 1975; Duellman and Trueb, 1986; Ford and Cannatella, 1993). Monophyly of Ranoidea is supported by both morphological (e.g., Duellman and Trueb, 1986; Ford and Cannatella, 1993) and molecular (e.g., Hay et al., 1995; Biju and Bossuyt, 2003; Hoegg et al., 2004; Roelants and Bossuyt, 2005) evidence. However, monophyly of Hyloidea is supported by molecular evidence only (e.g., Biju and Bossuyt, 2003 [but excluding heleophrynids, myobatrachids, nasikabatrachids, and sooglosids]; Hoegg et al., 2004; Roelants and Bossuyt, 2005), whereas morphological evidence is ambiguous (Ford and Cannatella, 1993). Hylid frogs are placed in Hyloidea, and some morphological data suggest that they are closely related to centrolenids (Duellman and Trueb, 1986; Ford and Cannatella, 1993). Some authors have considered pseudids (*Lysapsus*, *Pseudis*) to form a clade with hylids and centrolenids (e.g., Duellman and Trueb, 1986; Ford and Cannatella, 1993), but we consider

pseudids to be included within the hylid subfamily Hylinae, following da Silva (1998), Duellman (2001), and Darst and Cannatella (2004).

Given these considerations, we sampled two representatives of non-neobatrachian frogs (*Xenopus* and *Spea*), which were used to (graphically) root the tree. We also sampled two representative ranoids (*Gastrophryne* and *Rana*). We included six families of nonhylid hyloid frogs, including Allophrynidae (monotypic), Bufonidae (five genera and six species included), Centrolenidae (three genera, four species), Dendrobatidae (one genus, two species), Leptodactylidae (eight genera, eight species), and Myobatrachidae (two genera, two species). Sampling of nonhylids was most extensive within the leptodactylids, which are thought to be paraphyletic (e.g., Ford and Cannatella, 1993) and which may be closely related to hemiphractine hylids (Darst and Cannatella, 2004).

In some analyses, we also included a more extensive sampling of hylid species based primarily on mitochondrial data (in most cases, the 12S gene alone). These data included our own for 54 species and from literature sources (for the 12S gene), including Chek et al. (2001; 7 taxa), Darst and Cannatella (2004; 13 taxa), Moriarty and Cannatella (2004; 14 taxa), and Faivovich et al. (2004; 23 taxa). Our goal was to include as many hylid species as possible. Our sampling included representatives of 34 of the 40 recognized species groups of *Hyla* (based on taxonomy summarized in Frost [2001] but with modifications for Middle American taxa suggested by Duellman [2001]).

Morphological Data and Analysis

The morphological data set was assembled primarily from recent observations by J.J.W. of adult osteological ($n = 97$), adult external ($n = 19$), and larval external ($n = 20$) characters. Eight characters were used based entirely on data in the literature, including characters of myology ($n = 2$), life history ($n = 5$), and chromosomal number ($n = 1$). Here and throughout the article, we refer to this combined set of 144 characters as morphological, although not all characters may be considered morphological in the traditional sense. Characters are described in Appendix 1, and specimens examined are listed in online Appendix 2 (www.systematicbiology.org). Alcohol-preserved specimens were prepared as cleared-and-stained skeletal preparations using the method of Dingerkus and Uhler (1977). Osteological data for *Caudiverbera caudiverbera* were based on descriptions and illustrations in the literature (Lynch, 1978). In a few cases, we were not able to obtain molecular, external, osteological, and larval data for the same species, and some types of morphological characters (e.g., osteological, larval) were scored based on putative close relatives rather than conspecifics (see online Appendix 2).

Morphological data were coded as binary and multistate characters and were analyzed using parsimony and Bayesian methods. Multistate characters involving

quantitative variation along a single axis (length or extent of ossification of a structure, number of a meristic character) were ordered. Given that the states of these characters were delimited based on the assumption that similarity in trait values is informative, we believe it is only logical to use this assumption in ordering the states. The alternative is to assume that similarity in quantitative trait values is not informative, in which case many taxa would have to be given a unique state for these characters (because most taxa will not be identical), the states would be unordered, and these characters would therefore be largely uninformative. Other characters were unordered. Available versions of MrBayes do not allow for use of step matrices or >5 ordered character states. Therefore, it was not possible to use frequency coding of polymorphic characters or gap-weighting of quantitative characters (despite the advantages of these methods; Wiens, 1999, 2001), and a few multistate morphological characters had to be recoded for the Bayesian analysis by lumping states greater than five into a single state (this only affected a few taxa with extreme values for some characters). Given that we were using the morphological data to address higher-level relationships, sample sizes within species were limited (typically $n = 1$). Most polymorphism observed represented bilateral variation within an individual and was coded using the polymorphic method (see review in Wiens, 1999), given that frequency methods would be difficult to implement in MrBayes and the majority method can only be applied arbitrarily to a frequency of 50%. The morphological data matrix will be made available on the website of the journal.

The most parsimonious trees were sought using a two-step process. First, a heuristic search with 10,000 random-taxon-addition replicates and TBR (tree-bisection reconnection) branch swapping was performed using PAUP* 4.0b10 (Swofford, 2002). To facilitate thorough searching of tree space, a single tree was saved per replicate. A second analysis used 1,000 replicates and retained all shortest trees, keeping only trees equal to or shorter than those from the first analysis. If the shortest length found in the first analysis was not achieved in the second, then more replicates (up to 10,000) were examined. Support for individual branches was evaluated using nonparametric bootstrapping (Felsenstein, 1985), with 500 bootstrap pseudoreplicates per analysis. Each pseudoreplicate included 10 random-taxon-addition sequence replicates, again using TBR branch swapping and retaining a single tree per replicate. Bootstrap values $\geq 70\%$ were considered to be strongly supported, following Hillis and Bull (1993, but see their caveats). We readily acknowledge that this cut-off value of 70% is somewhat arbitrary, but is nevertheless preferable to using the overly conservative cut-off of 95%.

Bayesian analyses were performed using MrBayes version 3.0b4 (Huelsenbeck and Ronquist, 2001). Analyses of the morphological data used two replicate searches of 10.0×10^6 generations each, sampling every 1,000 generations, with four chains and default priors (i.e., equal state frequencies; uniform shape parameter;

all topologies equally likely a priori; branch lengths unconstrained:exponential). Log-likelihood scores were examined for equilibrium over time, and those trees generated before achieving stationarity were discarded as "burn-in." The majority-rule consensus of post-burn-in trees from each replicate analysis were examined to ensure that similar topologies and posterior probabilities for individual clades were obtained in each replicate. The phylogeny was estimated from the majority-rule consensus of post-burn-in trees pooled from the two replicates. A large number of generations was analyzed for the morphological data because preliminary analyses suggested that stationarity was achieved relatively slowly for these analyses (i.e., after 1.0×10^6 or 2.0×10^6 generations, depending on the model, see below). Unlike nonparametric bootstrap proportions, which are known to be conservative estimates of clade confidence (Hillis and Bull, 1993), recent simulation studies (e.g., Wilcox et al., 2002; Alfaro et al., 2003; Erixon et al., 2003; Huelsenbeck and Rannala, 2004) suggest that Bayesian posterior probabilities (Pp) may be less biased estimators of confidence and offer closer estimates of true clade probabilities. Although Bayesian analysis may be sensitive to weak, true signal (i.e., provide higher confidence for correct short internodes; Alfaro et al., 2003), it may also assign high support to short, incorrect internodes (e.g., Alfaro et al., 2003; Erixon et al., 2003). Given these considerations, clades with $Pp \geq 0.95$ were considered strongly (significantly) supported, but with the caveat that relatively high posterior probabilities for short internodes (particularly those with low bootstrap values) may be overestimates of confidence.

Bayesian analysis of the morphological data was performed using the maximum likelihood model for discrete morphological character data (Markov k or Mk) developed by Lewis (2001). The data were modeled under the assumption that only characters that varied among taxa were included (i.e., coding = variable; see Lewis [2001]). Analyses were performed both including and excluding a parameter for variation in rates of change among characters (using the gamma distribution; Yang, 1993, 1994). We then compared the fit of these models to our data using the Bayes factor (following Nylander et al., 2004). The Bayes factor (B_{10}) represents the ratio of the model likelihoods of the two models under consideration. Values of $2\log_e(B_{10})$ were calculated (i.e., two times the difference between the harmonic means of the log-likelihoods [post burn-in] of the two models) and values >10 were considered to be very strong evidence favoring one model over the other (Kass and Raftery, 1995). The harmonic mean of the log-likelihoods was calculated using the *sump* command in MrBayes, based on the pooled likelihood scores of the post-burn-in trees from the two replicate searches for each model. These analyses strongly favored the Mk + Γ model (Mk-v of Lewis [2001], $\ln L = -3,723.62$) over the Mk model ($\ln L = -3,850.67$), with a Bayes factor of 254.10. Only results from the former analysis are presented.

Molecular Data and Analysis

Four gene regions were sequenced. These included the mitochondrial ribosomal small subunit (12S; 1,078 bp; also including the adjacent tRNA-Phe and tRNA-Val), the mitochondrial NADH dehydrogenase subunit 1 gene (ND1; 1,218 bp; also including up to 372 bp of the adjacent 16S and tRNA genes), the nuclear proopiomelanocortin A gene (POMC; 547 bp), and portions of exons 2 and 3 of the nuclear proto-oncogene cellular myelocytomatosis (*c-myc*; 844 bp total). Standard techniques were used to extract DNA from frozen or ethanol-preserved tissues and amplify targeted gene sequences using the polymerase chain reaction (PCR). Primers are described in Table 2. Most PCR products were purified and sequenced directly using a Beckman CEQ or ABI 377 automated sequencer, whereas some were cloned prior to sequencing. Sequences were edited using Sequencher 3.1.1 and Se-Al 2.0. Voucher numbers and specimen localities are provided in online Appendix 3 (www.systematicbiology.org). Genbank accession numbers, including those for new sequences (AY819556 to AY819558) and those from previous studies, are listed in online Appendix 4 (www.systematicbiology.org). Basic properties of each of the molecular data sets (as well as the morphological and combined matrices) are described in Table 3. Although most of the initial 81 taxa had complete or nearly complete data for all five data sets, some lacked data for one or more genes or parts of genes, particularly for some distant outgroup taxa and ingroup taxa for which tissues were of poor quality (e.g., *Cryptobatrachus*). We discontinued our attempts to amplify these genes in these taxa only after several months of focused efforts failed.

Alignment of protein-coding sequences was straightforward, and was accomplished using Clustal X.1.81 (Thompson et al., 1994) using default parameters (gap opening = 15; gap extension = 6.666; delay divergent sequences = 30%; transition:transversion = 50%), with adjustments by eye. Sequences were translated into amino acids to check alignment and to look for potential stop codons. Alignment of the ribosomal sequences was less straightforward. The data were first analyzed using Clustal X.1.81, again with default parameters. Next, different gap-opening penalties were explored (12.5 and 17.5), and regions of the initial alignment that were different for other gap-opening penalties were considered ambiguously aligned and excluded from phylogenetic analyses. The non-neobatrachians *Spea* and *Xenopus* were initially excluded from these analyses to avoid removing much of the ingroup variation because of ambiguity created by these distant and highly divergent outgroups. These two taxa were then aligned to the ingroup sequences using default parameters, with minor adjustments made by eye. Next, the alignment was checked for conformity to models of secondary structure, primarily using stems and loops postulated for *Pseudacris regilla* in the European ribosomal RNA database as a starting point (<http://oberon.fvms.ugent.be:8080/rRNA/>) but also considering nucleotide complementarity in some

TABLE 2. Oligonucleotide primers used in this study.

Primer	Sequence (5' → 3')	Source
<i>12S</i>		
t-Phe-frog	ATAGCRCTGAARAYGCTRAGATG	Modified "MVZ.59" (Graybeal, 1997)
t-Val-frog	TGTAAGCGARAGGCTTTKGTAAAGCT	This study
12S-frogF ^a	CAAACRGGATTAGATACCCYACTATG	This study
12S-frogR ^a	TCRATTRYAGGACAGGCTCCTCTAG	This study
<i>ND1</i>		
16S-frog	TTACCCTRGGGATAACAGCGCAA	This study
tMet-frog	TTGGGGTATGGGCCAAAAGCT	This study
ND1-frog ^a	GAACGNAARGTNYTNGGNTAYAT	This study
ND1-frog2 ^a	YTGRCTRADCGRAANCGNGGRTA	This study
<i>c-mycexon2</i>		
cmyc1U	GAGGACATCTGGAARAARTT	Crawford (2003)
cmyc2F	ACVGARTTCCTGGGAGGGGACATGG	This study
cmyc-ex2d R	TCATTCAATGGGTAAGGGAAGACC	This study
cmyc-ex2e R	GAGCTGCAGCCGTGATGCTGAT	This study
cmyc-ex2e F	ATCAGCATCAACGGCTGCAGCTC	This study
<i>c-mycexon 3</i>		
cmyc3L	GTCTTCCTCTTGTCRITCTCYTC	Crawford (2003)
c-myc-ex3F	CCCACCAGTCCAGACCTCACCACAG	This study
c-myc-ex3R	GTTCTCTTTGAGTTTTAACTGTTC	This study
c-myc-ex3R2	CATAATACCCAAATCCCAAGTATGA	This study
c-myc-ex3F2	AYGTNCCYATYCAYCAGCACAACT	This study
c-myc-ex3R3	TCKCGNAKGAGYCKYCGCTCRIC	This study
<i>POMC</i>		
POMC-1	GAATGTATYAAAGMMTGCAAGATGGWCCT	This study
POMC-2	TAYTGRCCCTTYTTGTGGGCRIT	This study
POMC-3	TCTGCMGARTCWCCYGTGTTTCC	This study
POMC-4	TGGCATTYTTGAAAAGAGTCAT	This study
POMC-5	GGARCACTTYCGATGGGGYAAACC	This study
POMC-5-r	GGTTTRCCCCATCGRAAGTGYTCC	This study

^aInternal sequencing primer used for some taxa. Also, sometimes used as a PCR primer in combination with one of the original PCR primers. Primer sequence was designed using multiple hybrid taxa.

cases. Minor adjustments, intended to place insertions and deletions preferentially into hypothesized loop regions rather than stems, were made using Clustal X and by hand.

The placement of stems and loops can differ among species, potentially rendering use of a model from a single species as problematic. Nevertheless, the model of secondary structure for *Pseudacris regilla* is very similar to those from other hylid families in the European ribosomal database. For example, comparison of *P. regilla* to the bufonid *Atelopus varius* shows identical placement of stems and loops for 93.9% of 800 comparable base pairs (excluding gaps) and 94.1% similarity (out of 845 comparable base pairs) for the leptodactylid *Ceratophrys ornata*.

Even for the very distant outgroup *Xenopus laevis* (Pipidae) the placement of stems and loops matched *P. regilla* at 87.7% of the 929 sites. Thus, the *P. regilla* model should be adequate for analyses addressing relationships within hylids as well as the relationships of hylids to other anuran clades.

Molecular data were analyzed using parsimony and Bayesian methods. Each of the four data sets was initially analyzed alone to look for areas of incongruence that are strongly supported by two or more data sets, by comparing bootstrap values and Pp (Wiens, 1998c). Very little strongly supported incongruence was found (see results). Combined analyses were then performed, including (1) the two mitochondrial data sets alone, (2)

TABLE 3. Characteristics of the major data partitions analyzed in this study, from parsimony analyses based on the same set of up to 81 taxa. CI = consistency index (excluding uninformative characters); RI = retention index.

Partition (number of taxa)	Characters (pars. inf.)	Trees	Length	CI	RI
Morphology (79)	144 (140)	10,539	990	0.1836	0.5528
12S (81)	830 (384)	1,057	3,637	0.2010	0.4151
ND1 (80)	1,158 (628)	3	10,749	0.1256	0.2948
MtDNA (81)	1,996 (1,012)	2	14,530	0.1428	0.3188
POMC (79)	547 (274)	570	1,842	0.2760	0.5726
c-myc (80)	832 (307)	18	1,929	0.3024	0.5560
Nuclear DNA (80)	1,379 (581)	2	3,832	0.2843	0.5541
Combined molecular (81)	3,375 (1,593)	2	18,453	0.1705	0.3722
Combined data (81)	3,519 (1,733)	1	19,616	0.1696	0.3797

the two nuclear data sets alone, and (3) all four gene regions combined. As with the morphological analyses, most parsimonious trees were sought using two heuristic searches with TBR branch swapping (10,000 replicates followed by 1,000 or more replicates saving all shortest trees), and bootstrap support was evaluated with 500 bootstrap pseudoreplicates per analysis, each with 10 random-taxon-addition replicates.

Bayesian analyses require specifying a model of evolution, and combining data sets raises issues of how models and model parameters should be partitioned within and between genes. Bayesian model selection (e.g., Nylander et al., 2004) allows for evaluation of both models and partitioning strategies, but testing each possible combination of models and partitions would be difficult (i.e., given the many models that could be applied to each data set and the possible combinations of these models in the combined analysis). We therefore used a "mixed" strategy, in which hierarchical likelihood-ratio tests (implemented in MrModeltest version 2.0; Nylander, 2004) were used to pick reasonable models for the separate genes and comparison of Bayes factors was used to select the best partitioning strategy (Brandley et al., 2005; Wiens et al., 2005). For all four genes, analyses using MrModeltest selected the GTR+I+ Γ model (general time reversible [Rodriguez et al., 1990] with a proportion of sites invariable [Gu et al., 1995] and rates at other sites varying according to a gamma distribution [Yang, 1993, 1994]).

Analyses of model testing and partitioning were conducted on the data sets for 81 taxa, not the complete set of 198 taxa. We examined three partitioning strategies for the combined molecular data: (1) single partition for all genes combined (with the GTR+I+ Γ model); (2) separate partitions for each gene (each using the GTR+I+ Γ , but with parameters unlinked; total of four partitions); and (3) separate partitions for each gene, with additional partitions within each gene. The partitions within each gene were (1) stems and loops for the 12S gene (two partitions); (2) stem and loop regions for the 16S and tRNA regions adjacent to the ND1 gene, and first, second, and third codon positions within ND1 (five partitions); and (3) first, second, and third codon positions within the POMC and *c-myc* genes (three partitions per gene). Thus, in the most partitioned analysis of the combined molecular data, there were 13 total independent partitions. For each partitioning strategy, we analyzed the combined molecular data using two replicate searches with 2.0×10^6 generations each, sampling every 1,000 generations. A preliminary analysis for each data set using 4.0×10^6 generations suggested that 2.0×10^6 generations would be adequate for these analyses of ~81 taxa. Plots of log-likelihoods over time were examined for stationarity, and trees generated prior to achieving stationarity were discarded as burn-in. We summarized the harmonic mean of the log-likelihoods of the post-burn-in trees using the *sump* command in MrBayes, after pooling results from the separate analyses and checking to see that the separate analyses converged on similar log-likelihoods. We also compared the topologies and

clade posterior probabilities for each analysis as an additional test for stationarity. The phylogeny was estimated from the majority-rule consensus of the pooled post-burn-in trees from the two analyses. As described for the morphological data, values of $2 \log_e(B_{10})$ that were >10 were considered to strongly favor one model over the other. The harmonic means of the log-likelihoods for the post-burn-in trees were $\ln L = -76,192.85$ (single partition), $\ln L = -75,601.37$ (separate partition for each gene), and $\ln L = -74,944.65$ (separate partitions within and between genes). Thus, the most highly partitioned modeling strategy was strongly favored by these analyses. Bayesian analyses of the four genes separately, both with and without partitions within that gene, were also performed using the methods described above, and comparisons using the Bayes factor confirmed that the partitioned model provided a significantly better fit for each individual gene (results not shown). Analyses used four chains and default priors (i.e., Dirichlet for substitution rates and state frequencies; uniform for the gamma-shape parameter and proportion of invariable sites; all topologies equally likely a priori; branch lengths unconstrained:exponential).

Statistical Testing of Alternate Phylogenies

We did not perform commonly used statistical tests of alternate phylogenies (e.g., Templeton, 1983; Hillis et al., 1996; Huelsenbeck et al., 1996; Goldman et al., 2000). As currently implemented, these tests do not allow for combined analyses with partitioned models, thus requiring either use of inadequate models (for calculating likelihoods and/or simulating data), piecemeal analysis of the data, or analysis based on parsimony alone. Instead, we interpreted the statistical support for alternate phylogenies based on the posterior probabilities from the Bayesian analyses (i.e., monophyly of a clade is rejected when the alternate topology has $P_p \geq 0.95$).

Combined Analyses and Evaluation of Sampling Strategies

In general, we consider the best estimate of phylogeny to come from combined analysis of all the available data, but taking into account areas of strongly supported incongruence between data sets (Wiens and Reeder, 1997; Wiens, 1998c). Given that the data sets share the same phylogenetic history (as indicated by the lack of strongly supported incongruence), the large number of independently evolving characters in the combined analysis should provide the most accurate possible reconstruction of species phylogeny. In addition to the analyses undertaken to evaluate models and congruence, there were three main analyses in this study (all performed using parsimony and Bayesian methods described in the previous sections).

First, an analysis of the combined molecular and morphological data for the 81 "complete" taxa, exemplifying the bottom-up approach. Most taxa had complete or nearly complete data for all five data sets (but not all of these taxa had data for every single character). For two genera (*Colostethus* and *Gastrotheca*) we had molecular

data for two species but morphological data for only one; both genera were clearly monophyletic in the molecular analyses and we simply duplicated the morphological data for the congeneric species in the combined matrices. This was not a general method for character coding and was only used for these two species in the combined analysis.

Second, we performed an analysis that included all data for all taxa, including mitochondrial data (our own and from the literature) for many (117) additional taxa (198 taxa total). Most of the added taxa were hylids (115 of 117) and most (94 of 117) were based on 12S sequences only (~300 to 1,000 bp), including all taxa with data taken from the literature alone. However, 13 incomplete taxa included our data from the ND1 gene as well, and seven had data for one or more nuclear genes. Five taxa had data for ND1 and/or other genes, but lacked data from 12S (e.g., three species in the *Hyla bogotensis* species group for which we were unable to amplify the 12S gene). Thus, taxa included in this analysis spanned a broad range of levels of incompleteness (see online Appendix 4 for listing of which genes were present in each taxon). This analysis represented the combined approach, incorporating elements of both the top-down and bottom-up strategies.

Third, we analyzed the 12S data alone for all available taxa (193 taxa total), exemplifying the top-down approach. We then compared these results from 12S alone to those including all characters and taxa, to evaluate whether characters scored for only some taxa (morphology, ND1, POMC, *c-myc*) had an impact on the combined analysis (despite their missing data), or whether relationships in the combined analysis were instead determined only by the most taxonomically complete set of characters (12S).

For all three analyses we used parsimony analyses with equal weighting of all characters (methods described above). For Bayesian analyses, we used the Mk+ Γ model for the morphological data and the GTR+I+ Γ model for the molecular data (using the third partitioning strategy, with the largest number of unlinked partitions). For the second and third Bayesian analyses, which included nearly 200 taxa, we increased the number of generations sampled to 16.0×10^6 per search and sampled every 1000 generations.

We next evaluated the extent to which the phylogenetic placement of incomplete taxa can be strongly resolved. After the second analysis (all taxa, all characters), we quantified the level of completeness for each of the hylid taxa as the number of characters missing data divided by the total number of characters in the combined analysis. Hypothesized gaps were not counted as missing data, given our focus on incompleteness associated with unsampled characters. The outgroups and distantly related hemiphractine hylids were excluded; these groups contained few incomplete taxa and were only sparsely sampled in this study. We next quantified the level of support for the placement of each hylid species. For species placed on terminal branches (i.e., a species is the sister taxon of only one other species), the support index was simply the bootstrap value (parsimony) or Pp (Bayesian)

of the branch uniting that species and its sister taxon. For species placed on internal branches (i.e., a species that is the sister taxon of a clade of two or more species rather than a single species), the support index was the average of the branch immediately below the species (the clade including the species and its sister group) and the branch immediately above (the branch uniting its sister group). We then performed regression analyses of the relationship between the completeness of a taxon and the strength of support for its phylogenetic placement.

Admittedly, our view of "phylogenetic placement" is highly localized within a tree, and the inclusion of an incomplete taxon might be useful if that taxon could be strongly placed within some larger clade, regardless of the level of support for its specific placement within that clade. However, we think that our measure is conservative, in that it may err on the side of considering incomplete taxa to be more difficult to place confidently on a tree than they really are. Placement of a highly incomplete taxon next to a complete taxon may lead to poor support for the placement of the complete taxon as well as the incomplete taxon, a potential source of bias. If this generally is the case, there should still be lower support indices for incomplete taxa than complete taxa (i.e., support for complete taxa may be variable, but support for highly incomplete taxa should be consistently low).

Finally, we compared the level of support for the placement of each species in the combined analysis with their levels of support in the analysis of the most widely sampled data set (12S) alone. Almost all taxa have data for 12S (193 of 198), and many taxa had data for 12S only (94 of 198). Recent simulations (Wiens, 2003) suggest that the accuracy with which incomplete taxa are placed will depend on how accurately they can be placed by the most widely sampled set of characters alone, and not on their overall level of completeness. We predicted that the level of support for the placement of each taxon in the combined analysis (all taxa, all characters) would be correlated with the support for their placement in the analysis of the 12S data alone, and that this correlation would be much stronger than the correlation between support and overall levels of completeness (in the combined analysis).

Excluded Data

Given that we have included some relatively incomplete characters and taxa, our exclusion of other data requires justification. In theory, we could have added literature data from the cytochrome *b* and 16S genes for several hylids for this analysis (e.g., Chek et al., 2001; Darst and Cannatella, 2004; Faivovich et al., 2004). However, we were reluctant to add data from additional fast-evolving genes that are scored for a limited number of taxa because of the potential for long-branch effects in this scenario (see Wiens, 1998b). Also, we could have added taxa to our morphological data set using data from the literature, but this would have been difficult for many characters and taxa (e.g., osteological and larval characters in poorly known species), and we did not wish to code many of

these characters from literature observations alone. Some myological characters were excluded because their states have not been widely surveyed across hylids, or if they have been surveyed, the data have not been published (i.e., some characters from da Silva's [1998] dissertation discussed by Duellman [2001]). We excluded many 12S sequences of *Pseudacris* generated by Moriarty and Cannatella (2004) that represented multiple representatives of a single monophyletic species-level taxon. However, given that species limits within *Pseudacris* are uncertain, we included more than one individual from some species in order to represent distinct phylogeographic clades (and potentially distinct species) found by these authors.

RESULTS

Morphological Data

Parsimony and Bayesian analyses gave similar results for most analyses in this study, and differences generally involved branches only weakly supported by one or both methods. Given that we expect model-based methods to provide phylogenetic estimates that are as accurate or more accurate than those from parsimony (e.g., all data sets show demonstrably poor fit to the simple model of character change assumed by equally weighted parsimony), and in order to conserve space and paper, we present and describe trees from the Bayesian analyses only (for all types of data). However, we indicate congruent support from parsimony bootstrapping on all trees, and describe many parsimony results in the text. For all analyses, we figured trees with equal branch lengths, given that branch lengths are distorted by missing data in some taxa for many analyses.

Analysis of the morphological data alone (Fig. 2) yields many results that are surprising based on previous taxonomy and phylogenetic hypotheses. The traditionally recognized grouping of pseudids, allophrynids, centrolenids, and hylids is supported, with the important exception that the genus *Cyclorana* is placed with certain leptodactylids and ranids. Surprisingly, the Centrolenidae + *Allophryne* clade is nested deep within hylids, specifically within hylines. The hylid subfamilies Hemiphractinae, Pelodyadinae, and Phyllomedusinae are also nested within Hyliinae. Based on these results, the genus *Hyla* is paraphyletic with respect to other families (Centrolenidae, Allophrynidae) and other hylid subfamilies. Pelodyadines (minus *Cyclorana*) and phyllomedusines form a monophyletic group (see also Darst and Cannatella, 2004), but the pelodyadines are paraphyletic with respect to the monophyletic phyllomedusines. The former pseudid genera (*Pseudis*, *Lysapsus*) are successive sister taxa to the grouping of hylids, centrolenids, and allophrynids. There are relatively few "traditional" groups of hylids recognizable from the previous literature. However, monophyly of the 30-chromosome clade of *Hyla* is supported, as is a clade of large-bodied South American species (corresponding to the genus *Boana* as mentioned by Duellman, 2001). Outside of hylids, the results suggest the surprising nonmonophyly of ranoids, hylids, and neobatrachians. However, this may be due

to potentially misleading signals in the data (see Discussion). Most relationships are weakly supported in the Bayesian analysis ($P_p < 0.95$), but a few traditionally recognized groups, such as phyllomedusines and hemiphractines, are strongly supported (and also are recovered in the parsimony analysis).

Combined Molecular Data

Comparisons of separate analyses of individual nuclear and mitochondrial genes using parsimony and Bayesian methods revealed few strongly supported conflicts and many areas of congruence (results not shown). Data from the mitochondrial genes were then combined and analyzed, as were data from the nuclear genes. Comparisons of trees from the combined nuclear and combined mitochondrial data also showed little strong incongruence, and most of these cases involved different placements of single species within small clades. All cases of strongly supported incongruence are discussed briefly at the end of this section.

Analysis of the combined nuclear and mitochondrial genes shows strong support for many of the major phylogenetic conclusions of this study (Fig. 3). At the base of the tree the results show (1) monophyly of Neobatrachia, Ranoidea, and Hyloidea; (2) placement of dendrobatids within hylids rather than ranoids; and (3) placement of myobatrachids and the telmatobiine leptodactylid *Caudiverbera* as the sister group to all other hylids. In general, relationships among the hylid families are not strongly supported. Leptodactylids are shown to be nonmonophyletic, and although monophyly of subfamilies Ceratophryinae (*Ceratophrys*, *Lepidobatrachus*) and Eleutherodactylinae (*Eleutherodactylus*, *Ischnocnema*) are supported, monophyly of Leptodactylinae (*Physalaemus*, *Leptodactylus*) and Telmatobiinae (*Caudiverbera*, *Telmatobius*) are not. Monophyly of bufonids and centrolenids is supported, and there is strong support for placing allophrynids with centrolenids. However, the clade Allophrynidae + Centrolenidae is not closely related to hylids.

Although most hylid taxa are placed in a strongly supported clade, monophyly of hylids is not supported. Instead, both parsimony and Bayesian analyses place hemiphractine hylids (*Cryptobatrachus*, *Flectonotus*, *Gastrotheca*, *Hemiphractus*, *Stefania*) in a clade with several leptodactylid lineages, including Eleutherodactylinae. This conclusion is strongly supported by the Bayesian analysis. Mendelson et al. (2000) suggested that *Hemiphractus* is nested inside of *Gastrotheca*, but representative species of these genera in our analyses do not appear to be closely related, and monophyly of *Gastrotheca* is supported based on our limited sampling of species.

Apart from the hemiphractines, all other hylids sampled form a monophyletic group with three well-supported clades, corresponding to the subfamilies Hyliinae, Pelodyadinae, and Phyllomedusinae. Monophyly of hylids (excluding hemiphractines) and a clade of Pelodyadinae + Phyllomedusinae are both strongly supported in the Bayesian analyses. Within

Morphology

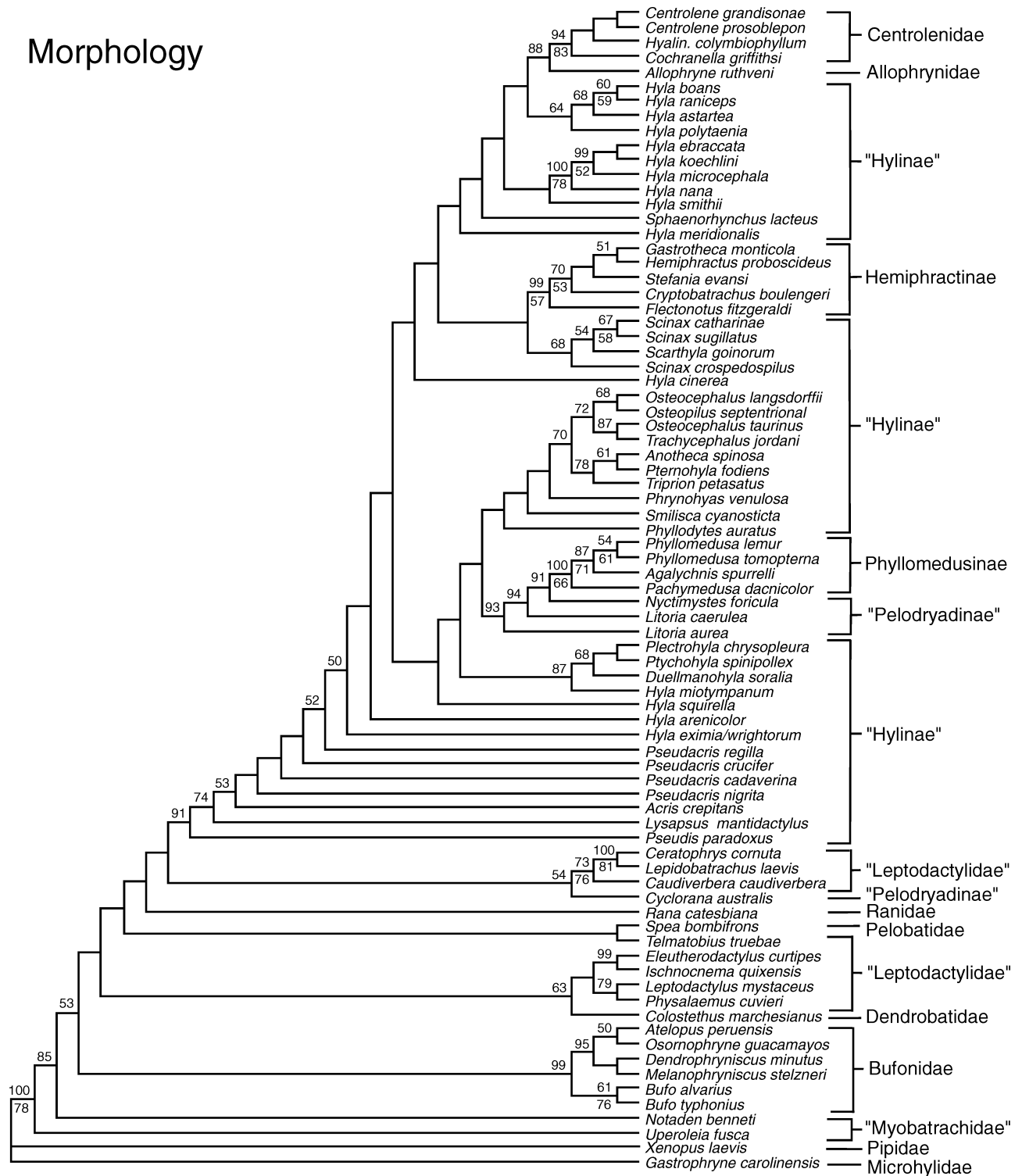

FIGURE 2. Phylogeny of hylid frogs based on morphological data alone (79 taxa). The topology is based on Bayesian analyses (harmonic mean $\ln L = -3,724.52$). Numbers above branches indicate Bayesian posterior probabilities; numbers below branches indicate bootstrap support values for clades that were also found in the parsimony analysis. For this and all subsequent figures, *Hyalin.* = *Hyalinobatrachium*.

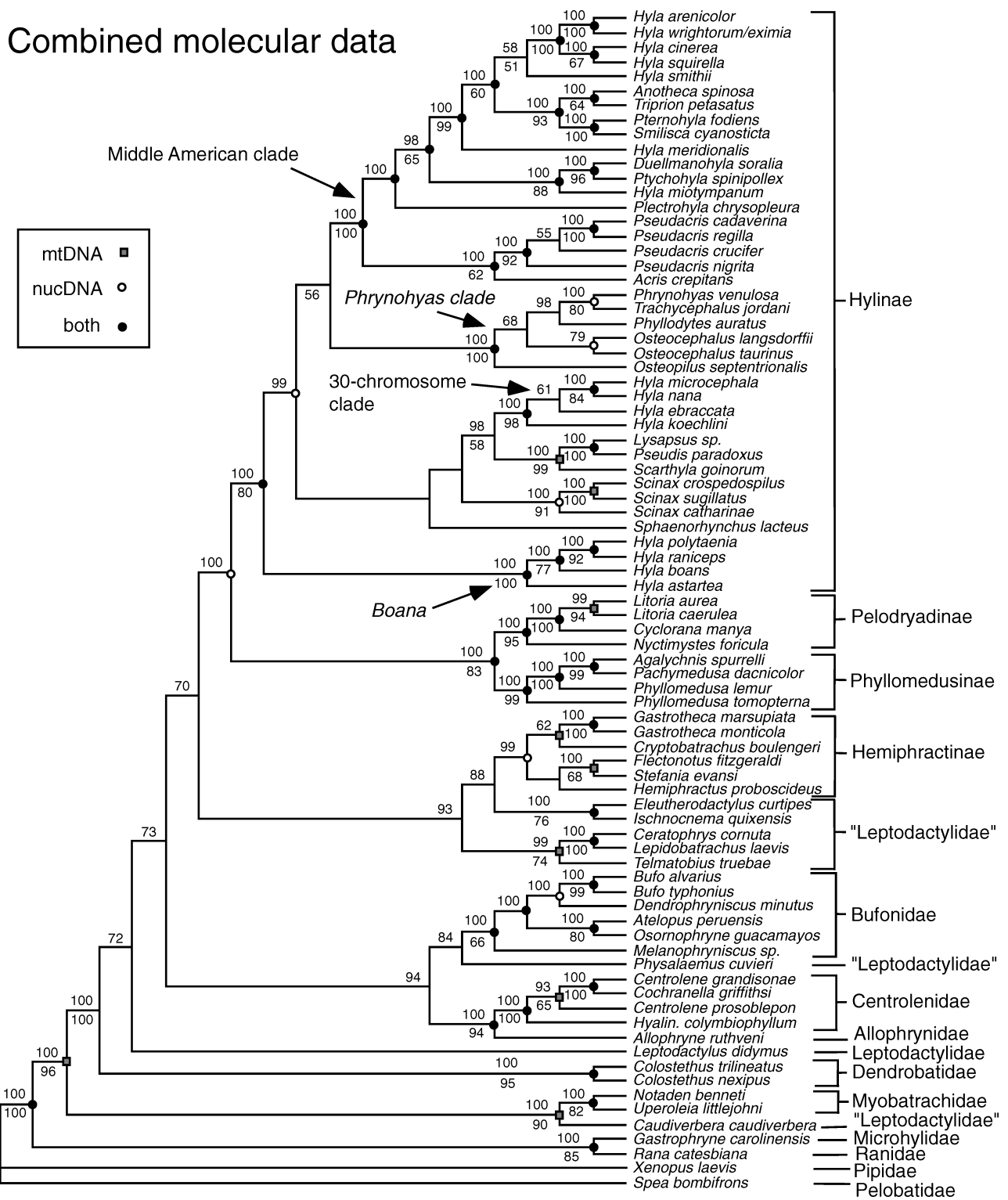

FIGURE 3. Phylogeny of hylid frogs based on the combined molecular data, including 81 taxa. The topology is based on Bayesian analyses (harmonic mean $\ln L = -74,944.65$). Numbers above branches indicate Bayesian posterior probabilities, numbers below branches indicate bootstrap support values for clades that were also found in the parsimony analysis. Symbols indicate clades that were also found in separate Bayesian analyses of the mitochondrial data and/or nuclear data (clades with no symbols are unique to the combined analysis).

Phyllomedusines, there is strong support for the paraphyly of *Phyllomedusa* with respect to *Agalychnis* and *Pachymedusa*.

Within Hylinae, there are several clades that are strongly supported by both parsimony and Bayesian analyses of the molecular data. These include (1) a clade of mostly large-bodied South American *Hyla*, representing the *albopunctata* (*H. raniceps*), *boana* (*H. boana*), *circumdata* (*H. astarterea*), and *polytaenia* (*H. polytaenia*) species groups (Duellman [2001] noted that the generic name *Boana* was available for this clade, and we use this name hereafter, foreshadowing later taxonomic changes); (2) the genus *Scinax*; (3) a clade consisting of the genus *Scarthyla* and the former family or subfamily Pseudinae (*Lysapsus* + *Pseudis*; we refer to these three genera as the *Pseudis* clade hereafter); (4) a clade of generally small-bodied Neotropical *Hyla* corresponding to the 30-chromosome clade of previous authors, including representatives of the *leucophyllata* (*H. ebraccata*), *microcephala* (*H. microcephala*), *nana* (*H. nana*), and *parviceps* (*H. koehlini*) species groups; (5) a clade of Neotropical genera including many with paired lateral vocal sacs (*Osteocephalus*, *Osteopilus*, *Phrynohyas*, *Phyllodytes*, *Trachycephalus*), referred to hereafter as the *Phrynohyas* clade; and (6) a clade that contains all of the endemic hyline genera of Middle American (*Anotheca*, *Duellmanohyla*, *Plectrohyla*, *Pternohyla*, *Smilisca*, *Triprion*) and North America (*Acris*, *Pseudacris*) and the endemic North American, Middle American, and Eurasian species of *Hyla* included in this analysis. Given that most of the genera and species of this clade occur in Middle America, we refer to it as the Middle American clade of hylines hereafter. The South American genus *Sphaenorhynchus*, represented by a single species in these analyses, represents a seventh clade. Relationships among these seven lineages are somewhat uncertain. However, the Bayesian analysis provides strong support for placing *Boana* (large-bodied South American *Hyla*) as the sister group to all other hylines, but this is not supported in the parsimony analyses. Both parsimony and Bayesian analyses place the 30-chromosome clade of *Hyla* with the *Pseudis* clade, and this clade is strongly supported by Bayesian analysis (Pp = 0.98) and moderately supported by parsimony bootstrap (58%). There is weak support from both parsimony and Bayesian analyses for placing the *Phrynohyas* clade with the Middle American clade.

Our results clearly demonstrate the polyphyly of the genus *Hyla*, with strong statistical support from the Bayesian analyses. They also suggest that many species of *Hyla* fall into three well-supported groups (*Boana*, the 30-chromosome clade, and the Middle America clade), a finding that is corroborated by subsequent analyses with greater taxon sampling. However, species of *Hyla* within the Middle American clade do not form a monophyletic group.

We describe below all cases of strongly supported incongruence between molecular data sets. We either resolve these conflicts (based on a majority of unlinked data sets) or else consider the relationships to be ambiguous in the combined-data tree (Wiens, 1998c). Comparison

of trees from Bayesian analyses of the combined nuclear genes and mtDNA data revealed five cases of strongly supported incongruence. (1) Analyses of POMC and combined nuclear data show Hyloidea as paraphyletic with respect to Ranoidea (specifically the leptodactylid *Caudiverbera* and the myobatrachids are the sister group to Ranoidea + all other Hyloidea), whereas Hyloidea is monophyletic in analyses of *c-myc*, mtDNA, and combined molecular data. We favor a monophyletic Hyloidea, given the concordance between *c-myc*, mtDNA, and morphology-based taxonomy. (2) Within bufonids, *c-myc* (and combined data) strongly support a relationship between *Dendrophryniscus* and the sampled species of *Bufo*, whereas other genes place *Dendrophryniscus* as the sister taxon of a clade containing *Atelopus*, *Bufo*, and *Osornophryne*. Given the surprising concordance between combined data and *c-myc* and our weak taxon sampling within bufonids, we consider placement of *Dendrophryniscus* within bufonids to be ambiguous. (3) *Litoria aurea* and *L. caerulea* form a monophyletic group in the mtDNA tree (supported by *c-myc* and ND1) and are paraphyletic with respect to *Cyclorana* in the nuclear tree (supported by POMC and 12S). We consider the relationships between these two species of *Litoria* to be unresolved. (4) The POMC data (and combined nuclear data) show strong support for placing *Scarthyla* with *Phrynohyas*, whereas *c-myc* and mtDNA data (and combined analyses) shows strong support for placing *Scarthyla* with *Pseudis* and *Lysapsus*. We hypothesize that the placement of *Scarthyla* by POMC is in error. (5) *Phrynohyas* and *Trachycephalus* are placed as sister taxa by the combined nuclear data, *c-myc*, and ND1 gene, whereas 12S and combined mtDNA place *Phrynohyas* with *Osteocephalus taurinus* (POMC is somewhat ambiguous, but favors the former hypothesis more than the latter). We favor the former arrangement.

Comparison of the two (linked) mitochondrial data sets shows only one case of strongly supported incongruence in the Bayesian analyses; the 12S data place *Pachymedusa dacnicolor* and *Phyllomedusa lemur* as sister taxa, whereas the ND1 data and combined nuclear data place *Pachymedusa* and *Agalychnis spurrellii* as sister taxa. We favor this latter arrangement.

There were three cases of strongly supported incongruence between Bayesian analyses of the two nuclear genes. One of these involves *Scarthyla* and is already discussed. Within centrolenids, POMC places *Centrolene prosoblepon* as basal, whereas *c-myc* (and mtDNA) place *Hyalinobatrachium* as the sister taxon to other sampled centrolenids. We favor the latter hypothesis, although the basal relationships within centrolenids are weakly supported in the combined analyses. *Hyla smithii* is strongly placed with *Anotheca*, *Pternohyla*, *Smilisca*, and *Triprion* by *c-myc* (and weakly by the combined mtDNA data) and with *H. arenicolor*, *H. cinerea*, *H. squirella*, and *H. wrightorum* by POMC and the combined molecular data. Given the strongly supported conflict, weak support from mtDNA, and weak support in the combined analyses, we consider placement of *H. smithii* to be ambiguous. The only strongly supported incongruence among

molecular data sets using parsimony involved the aforementioned conflict between nuclear genes over relationships within centrolenids.

Combined Morphology and DNA Data—Limited Taxon Sampling (Bottom-Up Approach)

Analyses of the combined molecular and morphological data (Fig. 4) give results that are very similar to those from analyses of the molecular data alone. In some ways, this similarity is not surprising given that there are many more molecular characters than morphological characters, and that many of the morphological results are only weakly supported (especially those that are incongruent with the molecular results). Major clades that are congruent between the separate molecular and morphological trees include monophyly of centrolenids, centrolenids + allophrynids, hemiphractines, phyllomedusines, phyllomedusine + pelodryadine clade (excluding *Cyclorana* in the morphology-based tree), the 30-chromosome clade of “*Hyla*,” and the *Boana* clade of “*Hyla*” (but only in the Bayesian analysis of the morphological data).

An interesting difference between the molecular and combined results is the placement of the hemiphractine hylids and the clade centrolenids + *Allophryne*. In analyses of the molecular data alone, these two clades are only distantly related to hylids within Hyloidea. In the combined Bayesian analysis, these clades are successive sister groups to the clade (Hylinae + (Pelodryadinae + Phyllomedusinae), although these relationships are not strongly supported. In the combined parsimony analysis, there is weak support for placing the clade Centrolenidae + *Allophryne* as the sister taxon of most hylids, whereas hemiphractines are placed with certain leptodactylids (as in the molecular analyses). There is an obvious explanation for this difference between the molecular and combined-data results. Most hylids (including hemiphractines), centrolenids, and *Allophryne* are characterized by arboreal habits and share derived morphological characters associated with this way of life, including intercalary phalangeal elements and modified toe pads (but note that some of these traits reverse in some terrestrial hylids). There was no strongly supported incongruence between the morphological and combined molecular trees, using parsimony or Bayesian methods.

Combined Analysis—Increased Taxon Sampling (Combined Approach)

Combined-data analyses with an additional 117 taxa (198 taxa total) were performed. Most of the added taxa were hylids for which only 12S data were available. Two analyses were performed (16×10^6 generations each), and both appeared to reach stationarity after $\sim 4 \times 10^6$ generations. However, one had a harmonic mean of the log-likelihoods somewhat higher than the other ($-99,679.96$ versus $-99,752.78$). Only results from the better fitting analysis are presented, but differences in the results of these analyses are discussed subsequently. The results of these two analyses were similar for most clades, and additional Bayesian analyses of this com-

bined data set (not shown) also produced congruent results.

Higher-level results from the Bayesian and parsimony analyses are similar to those from the analysis of the 81 complete taxa (Fig. 5). However, the Bayesian analysis strongly supports placement of hemiphractines with a clade of leptodactylids (unlike the Bayesian analyses with more limited taxon sampling, but more similar to results from parsimony analyses of the combined data and analyses of the molecular data alone). Parsimony and Bayesian analyses differ in the placement of Centrolenidae + *Allophryne*; Bayesian analyses strongly place this clade with hylids whereas parsimony analysis shows weak support for placing this clade with bufonids and some leptodactylids.

Within hylids, the major clades mentioned above remain the same (and the clades remain strongly supported), but many more species have been added to them (Figs. 5 to 7). These clades include Hylinae, Pelodryadinae, Phyllomedusinae, *Scinax*, *Boana*, 30-chromosome “*Hyla*,” and the *Phrynohyas*, *Pseudis*, and Middle American clades. The relationships among the major clades largely remain stable after the addition of these taxa (and are generally congruent between parsimony and Bayesian analyses), including (1) placements of phyllomedusines and pelodryadines as sister taxa ($P_p = 1.00$); (2) basal placement of *Boana* within Hylinae ($P_p = 1.00$); (3) the grouping of *Scinax*, *Sphaenorhynchus*, 30-chromosome “*Hyla*,” and the *Pseudis* clade with $P_p = 0.89$; (4) placement of the *Pseudis* clade with the 30-chromosome “*Hyla*” ($P_p = 1.00$); and (5) the grouping of the *Phrynohyas* and Middle American clades ($P_p = 0.92$). However, relationships among these major clades are not strongly supported by parsimony analysis, and some only approach strong support in Bayesian analyses.

In general, the results suggest that highly incomplete taxa can be added successfully to both parsimony and Bayesian analyses. All of the 117 incomplete taxa added fall into the major clades that are predicted by previous taxonomy, and the monophyly of these major clades remains strongly supported despite the inclusion of incomplete taxa. Thus, most of the species that fall into the *Boana* clade belong to species groups of “*Hyla*” that were predicted to belong to this group by Duellman (2001); all exceptions are species groups that simply were not mentioned by Duellman (2001). The same is true for the 30-chromosome clade of “*Hyla*,” *Scinax*, pelodryadines, and phyllomedusines. Similarly, additional taxa that fall into the Middle American clade occur in Middle America, North America, or Asia (Fig. 7). It should be noted that these major clades are strongly supported by analyses of the molecular data alone and our hypothesis that these species have been correctly placed is not based on congruence with prior taxonomy alone.

There was one interesting exception to this general pattern. In the Bayesian analysis with the less optimal mean log-likelihood (which was not used or figured here), the hylid *Scinax elaeochraoa* was placed near the base of the entire tree, with very strong support. Otherwise, the results of this Bayesian analysis were extremely similar to

Combined molecular and morphological data

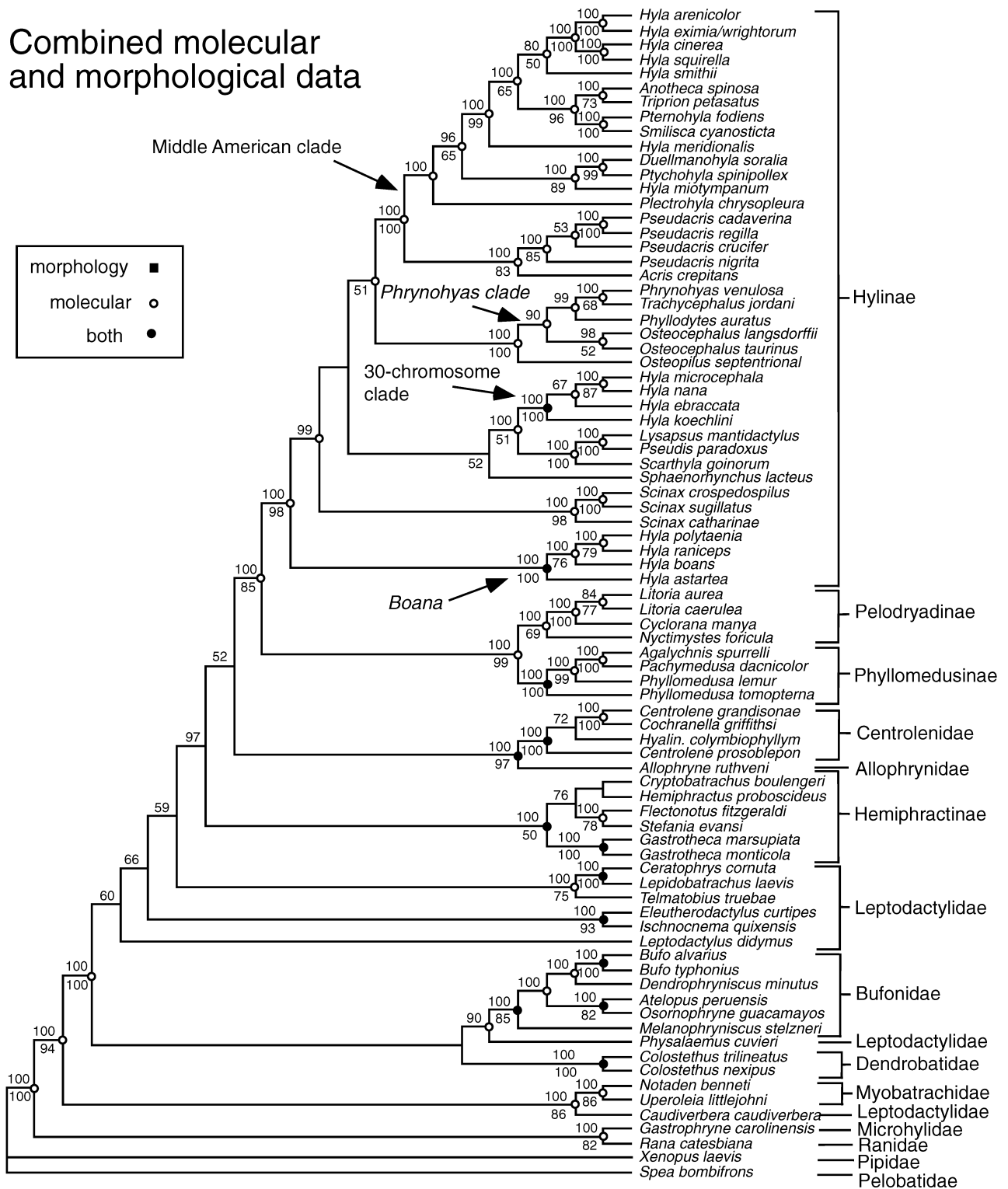

FIGURE 4. Phylogeny of hyloid frogs based on combined molecular and morphological data, including 81 taxa. The topology is based on Bayesian analyses (harmonic mean $\ln L = -79,185.84$). Numbers above branches indicate Bayesian posterior probabilities; numbers below branches indicate bootstrap support for clades that were also found in the parsimony analysis. Symbols indicate clades that were also found in separate Bayesian analyses of the morphological data and/or molecular data (clades with no symbols are unique to the combined analysis).

Combined molecular and morphological data

All taxa

Part 1 of 3

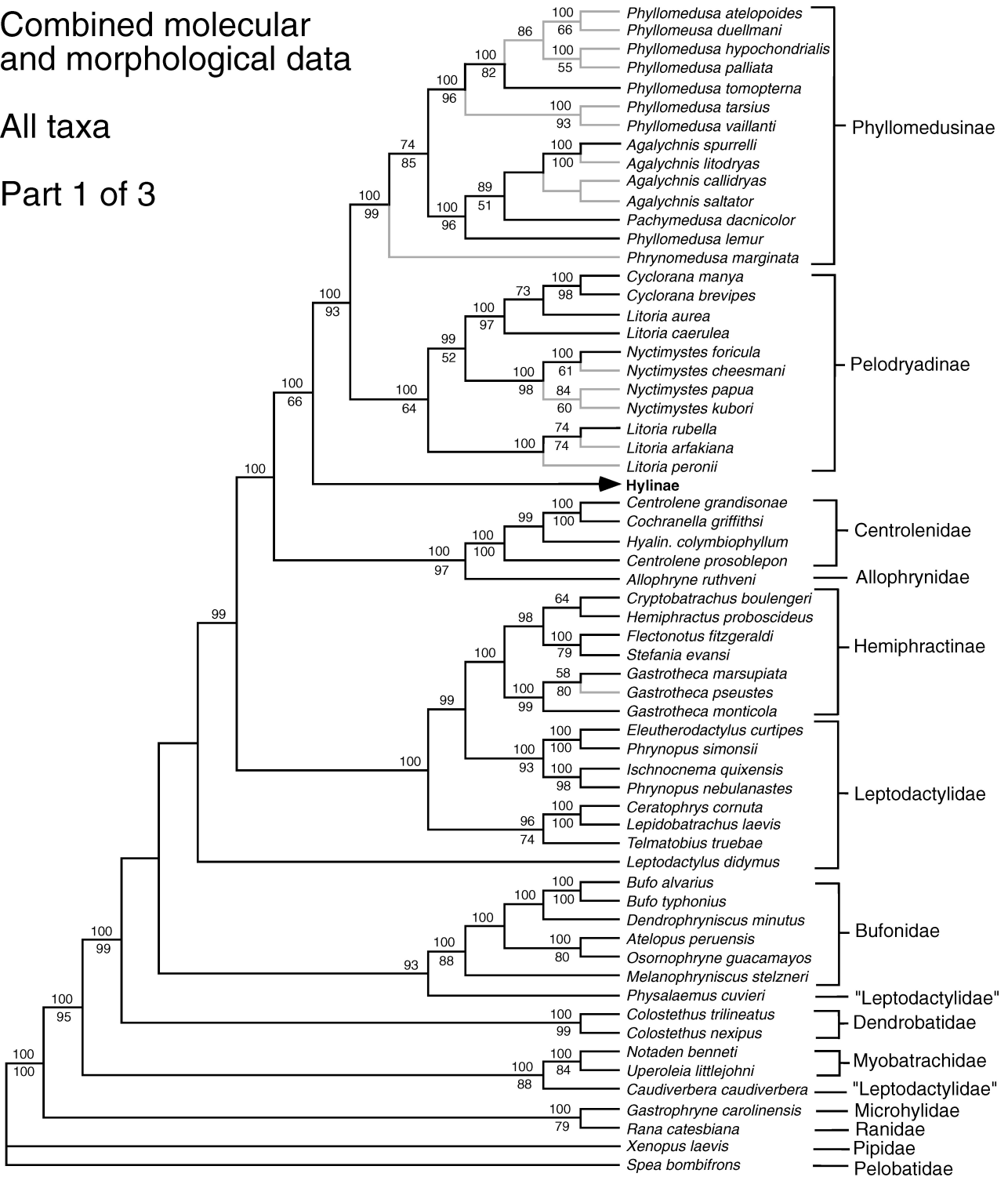

FIGURE 5. Phylogeny of hyliid frogs based on combined molecular and morphological data, including 198 taxa. Branches leading to highly incomplete taxa (>75% missing data) are shown with gray lines; branches associated with more complete taxa are black. The topology is based on Bayesian analyses (harmonic mean $\ln L = -99,679.96$). Numbers above branches indicate Bayesian posterior probabilities; numbers below branches indicate bootstrap support for clades that were also found in the parsimony analysis.

Combined molecular
and morphological data

All taxa

Part 2 of 3

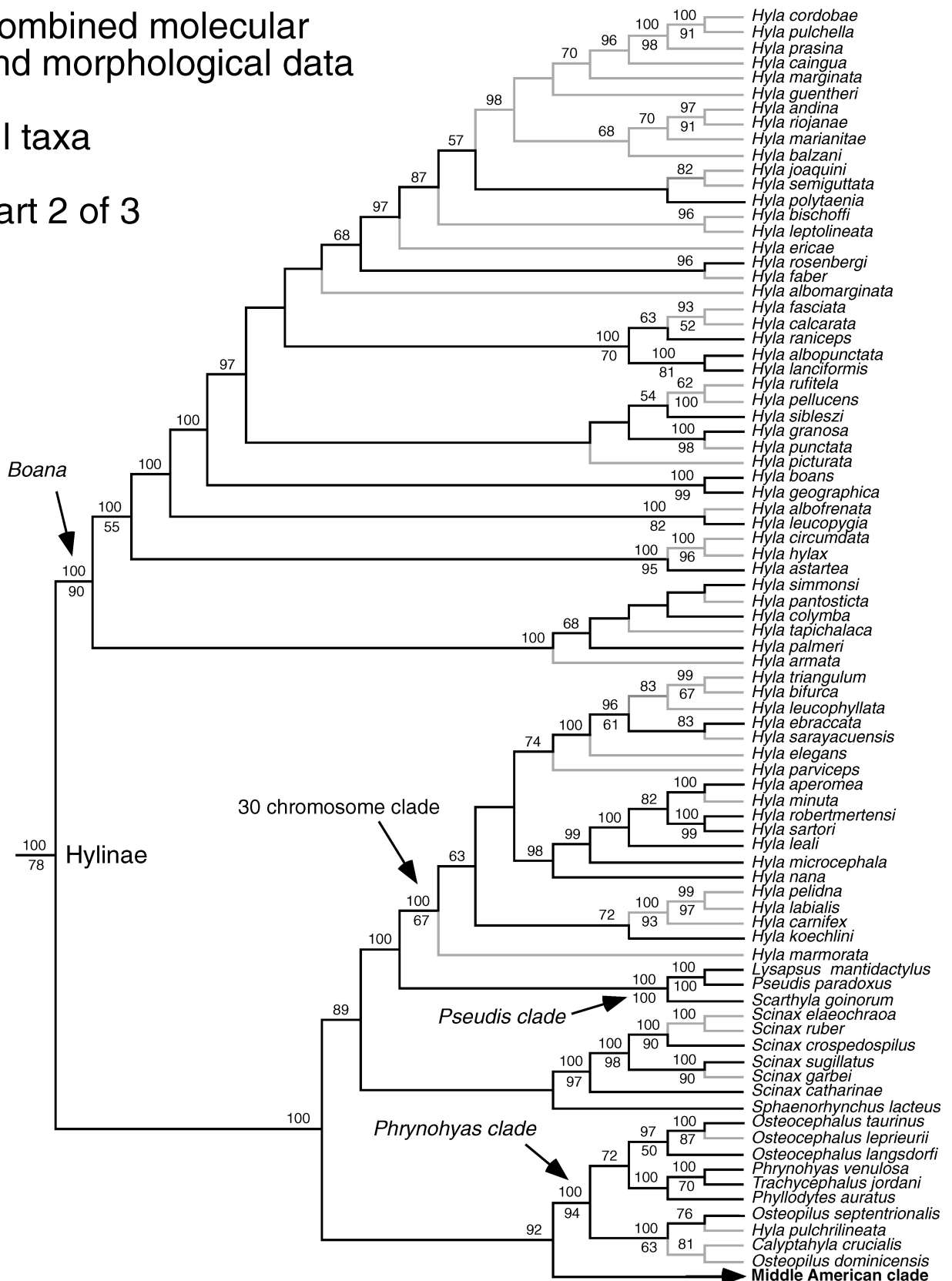

FIGURE 6. Phylogeny of hylid frogs based on combined molecular and morphological data, including 198 taxa, continued from Figure 5.

Combined molecular
and morphological data

All taxa

Part 3 of 3

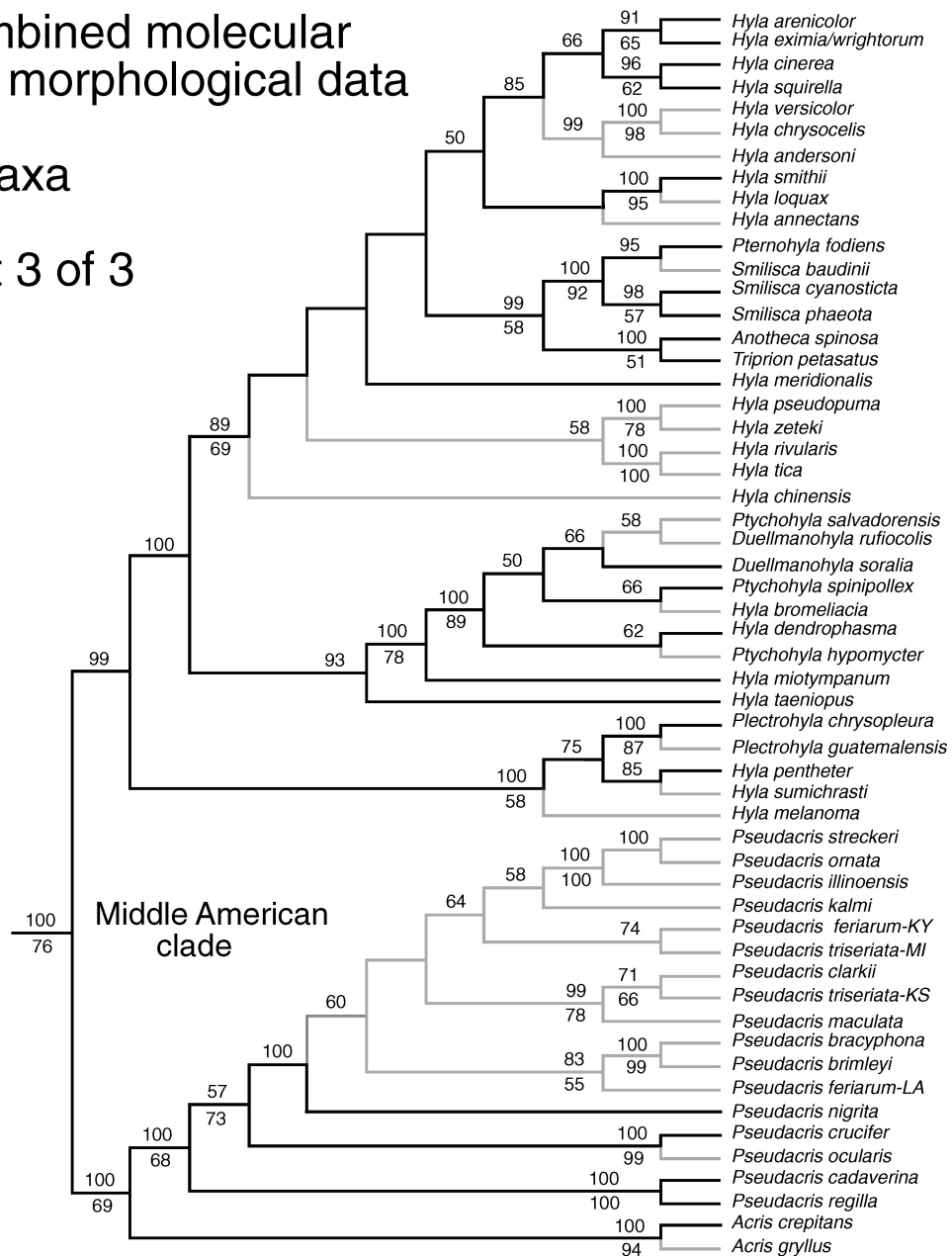

FIGURE 7. Phylogeny of hylid frogs based on combined molecular and morphological data, including 198 taxa, continued from Figures 5 and 6.

the replicate shown here. Curiously, this species is not unusually incomplete (76.2% missing data), and there are 92 other taxa with at least this much missing data and several with >90% missing data. Furthermore, the parsimony analysis and the other Bayesian analysis (Figs. 5 to 7) seem to place this species “correctly” (with other *Scinax*) with relatively strong support.

In addition to being placed “correctly” at larger phylogenetic scales, most incomplete taxa are placed at the fine scale with relatively strong support, despite extensive missing data. We address the relationship between support and completeness more quantitatively in the last

section. The addition of these taxa also has many implications for the generic-level taxonomy of hylid frogs, which we discuss in detail in the Discussion, under “Hylid Phylogeny and Taxonomy.”

12S Data Only (Top-Down Approach)

The 12S data set alone consists of up to 1,078 characters per taxon, and although a few taxa have only ~300 bp, the average proportion of missing data per taxon is only 8.9% (see online Appendix 4 for completeness of each taxon for this gene). Two Bayesian analyses of

the 12S data were performed using 16×10^6 generations each. Although both seemingly reached stationarity with similar log-likelihoods (harmonic means of $-27,961.97$ and $-27,961.27$), the first analysis seemed to reach stationarity only after $\sim 14 \times 10^6$ generations, whereas the second reached this after less than 4.5×10^6 generations. Only results from the second analysis are presented (i.e., given the larger number of data points), although the results were generally very similar. Most results of the second analysis are also supported by additional analyses of these data using fewer generations (results not shown).

Analyses of the 12S data alone (193 taxa) supports many of the clades found in the analyses of the combined data, either strictly or with a few exceptions (Figs. 8 to 10). Clearly, the 12S data are critical in placing many of the taxa in the combined analysis. However, some taxa seemingly are misplaced, and there are some important differences between these results and those based on the combined data. For example, the 12S data alone show no support for monophyly of hemiphractines, hylines, nor the clade of hylines, pelodyradines, and phyllomedusines. Particularly problematic is the nesting of the leptodactylid *Physalaemus cuvieri* inside of hylines, and placement of some hemiphractines (and some leptodactylids) with the pelodyradine + phyllomedusine clade (which is only weakly supported). Within hylines, the same major clades are generally supported as in other analyses (e.g., *Scinax*, *Boana*, 30-chromosome *Hyla*, and the *Phrynohyas*, *Pseudis*, and Middle American clades). However, most of the relationships among these major clades differ from those in other analyses (e.g., *Boana* is no longer basal, the *Pseudis* clade is not the sister taxon of the 30-chromosome "*Hyla*") and all of the relationships among these clades are only weakly supported ($P_p < 0.80$). Relationships within the Middle American clade are generally similar to those based on the combined analysis (Fig. 10), but *Pseudacris* and the *Acris* + *Pseudacris* clade are not supported as monophyletic. One obvious interpretation of these differences between the 12S and combined analyses is that the addition of the four other data sets (morphology, ND1, POMC, *c-myc*) contributes positively to the combined analysis, despite the fact that these data sets are scored for a much smaller set of taxa than 12S.

The results from the parsimony analysis of the 12S data alone (not shown) are similar but in some ways are even "worse." For example, dendrobatids and a bufonid (*Melanophryniscus*) are placed within hylines, in addition to the leptodactylid *Physalaemus*.

Support and Incompleteness

We quantified the level of completeness for each of the species of hylids (excluding hemiphractines) in the combined analyses including all 198 taxa and determined the level of support for the placement of each of these species (Fig. 11). We found no relationship between the completeness of a taxon and the level of support for its phylogenetic placement using either Bayesian anal-

ysis ($r^2 = 0.014$; $P = 0.1384$) or parsimony ($r^2 = 0.021$; $P = 0.0655$). In contrast, there was a significant relationship between levels of support in the combined analyses and in the analyses of the 12S data alone (Fig. 11c, d), for both Bayesian analysis ($r^2 = 0.304$; $P < 0.0001$) and parsimony ($r^2 = 0.764$; $P < 0.0001$). We suspect that the weaker relationship found in the Bayesian analysis results from the relative paucity of weak and intermediate support values using this method (i.e., many clades are very strongly supported). There was no relationship between levels of completeness of taxa in the combined analysis and levels of support for their placement in the 12S data (Bayesian $r^2 = 0.002$; $P = 0.5397$; parsimony $r^2 = 0.005$; $P = 0.3856$).

DISCUSSION

Sampling Strategies for Speciose Clades

Hylids clearly pose a difficult problem for phylogenetic analysis, one that blurs the distinction between "higher-level" and "species-level" problems (e.g., some clades of species within the polyphyletic genus "*Hyla*" may be as old or older than the subfamilies Pelodyradinae and Phyllomedusinae). Our results suggest that neither a bottom-up approach (few taxa, many and slower characters) nor a top-down approach (many taxa, fewer and faster characters) is satisfactory on its own. The bottom-up approach provides strong support for many relationships at many phylogenetic scales in this study. However, it fails to address the relationships of the majority of species that were included in this study. The top-down approach addresses the relationships among (almost) all of these species, but fails to recover many higher-level relationships that are strongly supported using the bottom-up approach. In contrast, the combined approach seemed to provide the best of both worlds, providing resolution and strong support for both higher-level and species-level relationships.

An obvious consequence of the combined approach is that the data matrix contains large amounts of missing data (e.g., the average proportion of missing data cells per species for non-hemiphractine hylids is 52.6%). There are two ways in which negative effects of missing data might have played a role in our analyses. First, the combined analyses might have been unable to resolve the position of species scored for only one of the data sets (i.e., 12S). Second, addition of the more taxonomically limited data sets (morphology, ND1, POMC, *c-myc*) might have had no influence on relationships established by the most well-sampled data set (12S). Neither of these predictions was supported.

We found that the phylogenetic placement of species that are highly incomplete can be resolved in the context of the combined analysis, despite large amounts of missing data. In other words, inclusion of these taxa did not necessarily create large polytomies of unresolved or weakly supported relationships, as observed in some analyses that have included highly incomplete fossil taxa (e.g., Gauthier, 1986; Wilkinson and Benton, 1995; Gao



FIGURE 8. Phylogeny of hylid frogs based on 12S data only, including 193 taxa. The topology is based on Bayesian analyses (harmonic mean $\ln L = -27,961.27$). Numbers above branches indicate Bayesian posterior probabilities; numbers below branches indicate bootstrap support values for clades that were also found in the parsimony analysis.

12S alone

all taxa

part 2 of 3

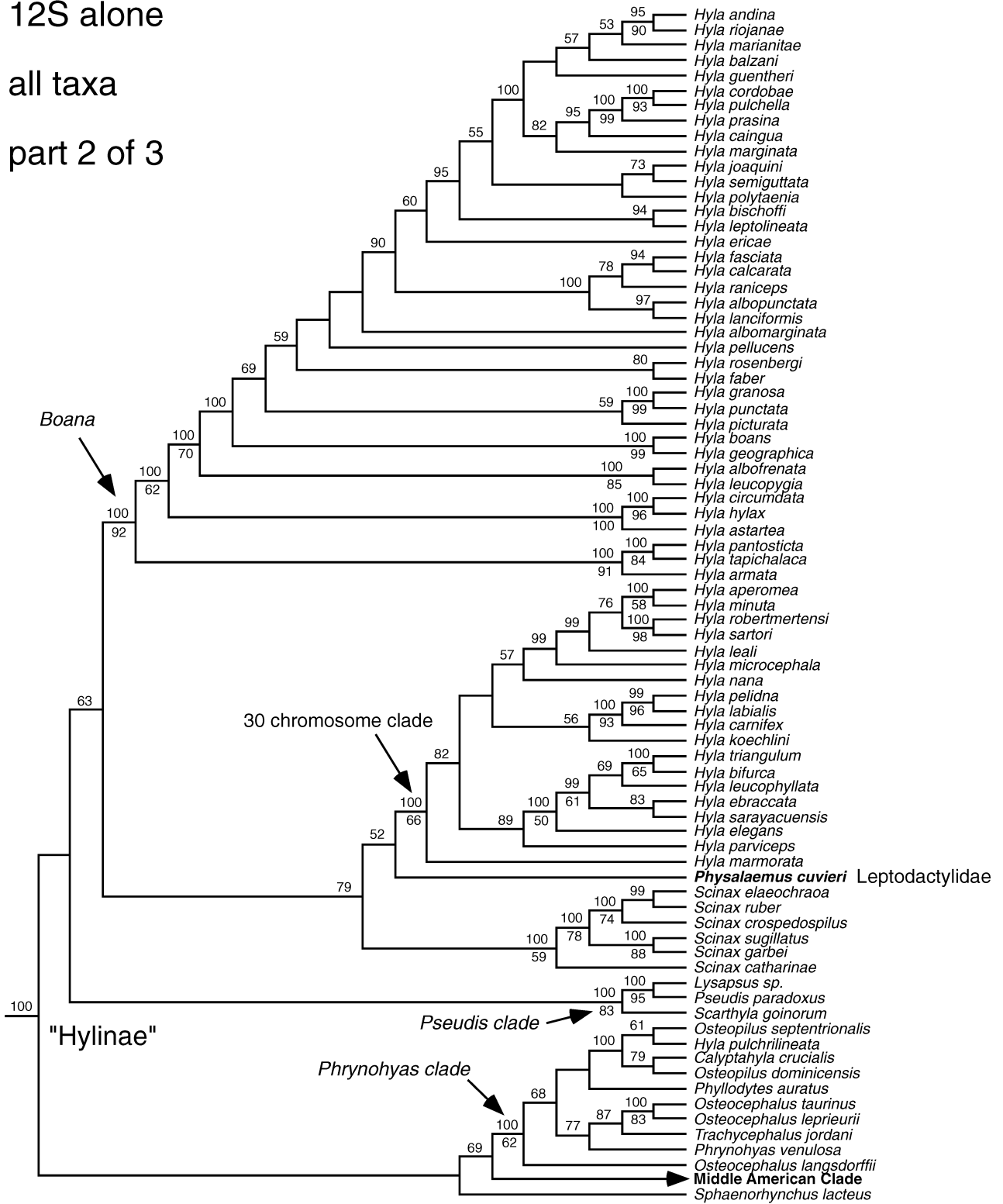

FIGURE 9. Phylogeny of hylid frogs based on 12S data only, including 193 taxa. Continued from Figure 8.

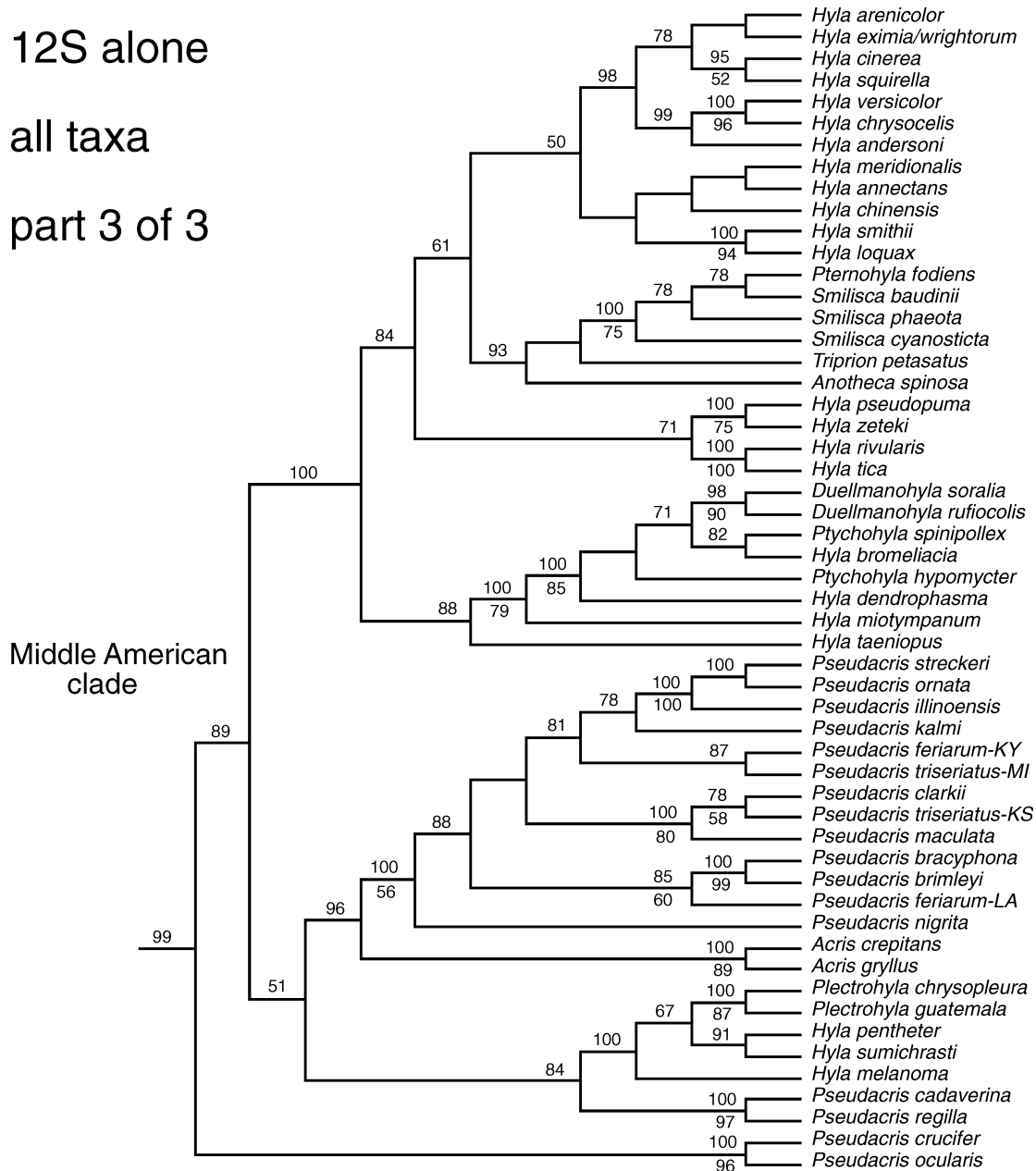

FIGURE 10. Phylogeny of hylid frogs based on 12S data only, including 193 taxa. The topology is based on Bayesian analyses. Continued from Figure 9.

and Norell, 1998). Furthermore, the incomplete taxa were placed into the major clades expected by prior taxonomy, suggesting that they may have been placed correctly (at least at the broadest phylogenetic scales). For example, all eight species that we included that were <10% complete (i.e., >90% of characters missing data) were placed in the expected clades by parsimony and Bayesian analyses. The support for the placement of these incomplete taxa in the higher-level clades was consistently high. Thus, even though Pelodyadinae, Phyllomedusinae, *Boana*, *Scinax*, 30-chromosome *Hyla*, *Phrynohyas* clade, and Middle American clade each contained many in-

complete taxa (some <10% complete), the Bayesian support (Pp) for each of these clades was 1.00, with bootstrap values from 64% to 99%. Again, it should be noted that these major clades are concordant with prior taxonomy but are also strongly supported by molecular data alone.

At finer phylogenetic scales, the support for the species-level placement of incomplete taxa was also often high. Levels of completeness explained less than 5% of the variation in levels of support. Instead, the levels of support in the analysis of the 12S data alone provided a much stronger predictor of levels of support

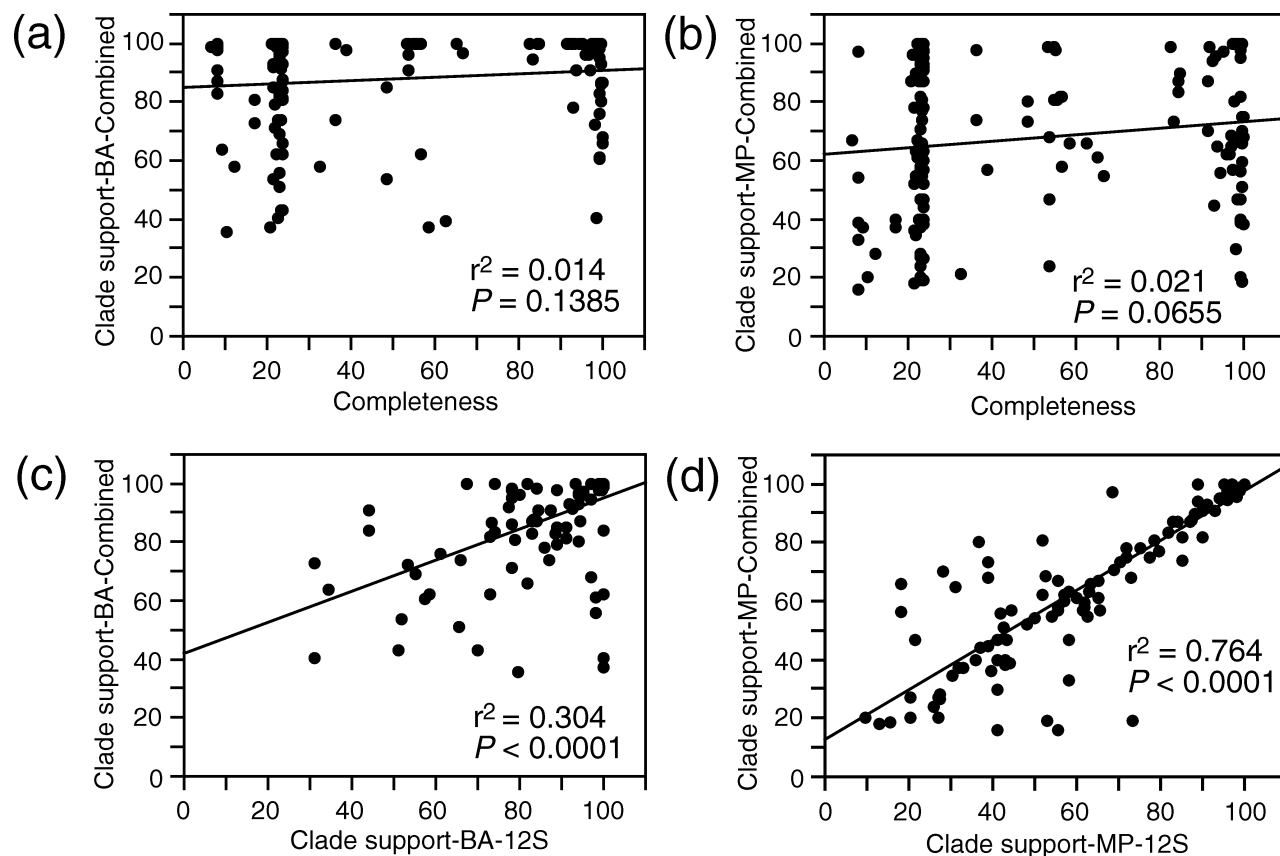

FIGURE 11. Relationships between the support for the placement of hylid taxa in the combined analysis of all the data and the completeness of the taxon in the combined analysis (1 – percent missing data cells) using Bayesian (a; BA) and parsimony (b; MP) methods, and between support in the combined analysis and support in the analysis of the 12S data alone (c and d).

in the combined analysis than did levels of completeness. These results match predictions from simulations (Wiens, 2003), which suggest that the amount of missing data alone does not prevent the accurate placement of incomplete taxa and that the success of their placement instead depends primarily on how well they can be placed by the data sets for which they have been scored. We note that our study may be the first to quantitatively test the relationship between clade support and completeness.

We also found that the sets of characters that were scored for a limited number of species did influence higher-level relationships. Thus, the relationships estimated from 12S alone differed from those estimated in the analyses of all taxa that included additional data sets. Furthermore, many clades that were strongly supported in the combined analyses were weakly supported or unresolved in analyses of the 12S data alone. Many higher taxa that were supported as monophyletic in various analyses of the separate data sets were not recovered in analyses of the 12S data alone (e.g., hylines, hemiphractines). Again, these results seem to support predictions from simulations, which show that the addition of characters with missing data can increase phylogenetic accuracy, despite the incompleteness of these characters (Wiens, 1998b).

We acknowledge that similar analyses in other groups might not necessarily match the results of this study. One key factor that may have allowed for placement of the incomplete taxa was that the 12S gene was scored for almost all taxa and generally seemed to contain sufficient characters and phylogenetic signal for this purpose. The phylogenetic placement of incomplete taxa may not have been possible (or as effective) if this fragment was shorter in all taxa; simulations suggest that accurate placement of incomplete taxa depends on the absolute number of characters for which they have data (Wiens, 2003). These simulations also suggest that the placement of taxa may be less accurate if there is no set of characters that is complete in all or most taxa (e.g., 12S) and if rates of change are very high. Having 12S data seemed to be critical for the well-supported placement of incomplete taxa in the combined analyses; the five species that lacked 12S data had significantly lower mean support for their placement (mean Bayesian support = 0.492; mean parsimony support = 52.3%) than species that had 12S data (Bayesian mean = 0.8913, lower 95% confidence interval 0.8662; parsimony mean = 67.89%, lower 95% confidence interval 63.86%).

Conversely, the addition of the incomplete character sets (i.e., morphology, ND1, nuclear genes) may have

been less helpful if the set of characters scored in all taxa was larger and perhaps more slowly evolving (i.e., if 12S strongly resolved higher-level relationships that were concordant with results from other data, there would have been little room for improvement). We also acknowledge that our combination of the 'top-down' and 'bottom-up' approaches is certainly not ideal. For example, it would obviously be better to have complete character data for all 198 taxa (including multiple nuclear genes and morphology).

In general, our results support predictions from simulations and offer considerable hope for the prospects of including incomplete taxa in combined-data analyses (see also Phillippe et al., 2004; Driskell et al., 2005) and for developing sampling strategies for highly species-rich clades that are time and cost effective. However, the results should not be taken as an excuse for the uncritical inclusion of taxa or characters. For example, simulations suggest that there are situations where adding highly incomplete taxa can lead to poorly resolved trees (i.e., when there are few informative characters overall; Wiens, 2003) and when adding highly incomplete characters might decrease phylogenetic accuracy (particularly when a large number of rapidly evolving characters are sampled in a few distantly related taxa; Wiens, 1998b). We also note that the effects of extensive missing data on Bayesian analysis are in need of much additional study, including the issue of how missing data might effect convergence.

The issue of sampling strategies has received much attention in the recent phylogenetic literature, but mostly in terms of debating the relative merits of sampling taxa versus characters. In general, our results suggest the importance of considering sampling "shortcuts" that may be possible by including incomplete taxa and characters.

Rates of Change

Our results also reinforce the importance of considering rates of character change in addition to the number of characters alone. Even though there are nearly twice as many mitochondrial characters as nuclear (Table 3), many important higher-level clades are supported by nuclear data alone (e.g., hylids exclusive of hemiphractines, hylines above *Boana*). Furthermore, the Bayesian trees based on the combined analysis of all the molecular and morphological data are slightly more similar to those from the combined nuclear data alone (71% of clades shared) than to those based on the combined mtDNA data (69% clades shared). Thus, the contribution of the nuclear data is much greater than might be expected based on the number of characters alone (or even the number of parsimony-informative characters). The explanation for this is obvious; the mitochondrial genes may have nearly twice as many characters, but they also appear to have about twice as much homoplasy as the nuclear genes (Table 3), which seems to diminish their effectiveness.

Misleading Morphological Signals

A surprising result of this study is the extent to which the morphological results are discordant with both the molecular results and with current anuran classification. In other words, the molecular results seem more congruent with the morphology-based taxonomy than they are with the morphology-based trees. The discordant morphological results seem to reflect the combination of two different factors: (1) misleading phylogenetic signals in the morphological data, which involve suites of weakly correlated characters; and (2) overall morphological conservatism, such that the misleading signal overpowers the true phylogenetic signal for a given case.

There seem to be several different misleading phylogenetic signals in the morphological data. All of these apparently are associated with suites of characters that evolve together in some parts of the phylogeny but not others. Thus, although the characters within these suites are seemingly not strictly independent (i.e., they do not share identical distributions among taxa), they may not be fully independent either. Independence of characters is a fundamental assumption of all phylogenetic methods, and violations of this assumption can potentially lead to results that are both wrong and statistically well supported (e.g., de Queiroz, 1993; Emerson and Hastings, 1998). We describe these misleading signals and the associated suites of related characters below.

One misleading signal seemingly is associated with the highly derived tadpole morphologies of microhylids and pipids (e.g., laterally placed spiracle, character 117; loss of labial tooth rows and beaks, characters 120 to 122; presence of lateral labial folds, character 128). This suite of characters contributes to the nonmonophyly of neobatrachians and ranoids observed in the analyses of the morphological data alone. This seemingly incorrect clade is strongly supported by parsimony and Bayesian analysis of the morphological data but is contradicted by the nuclear and mitochondrial genes and traditional morphology-based taxonomy (and many characters of adult morphology).

Another misleading signal is associated with the evolution of a highly ossified skull. There is a large suite of characters that reflect an overall increase in cranial ossification. These characters do not share identical distributions among taxa, but they seem to evolve together on some branches, producing misleading results in some cases. For example, these characters (nasal-maxilla articulation, character 9; cranial exostosis, character 11; squamosal-maxilla articulation, character 20) help place the pelodryadine hylid *Cyclorana* and the telmatobine leptodactylid *Caudiverbera* in a clade with the ceratophryine leptodactylids (*Ceratophrys*, *Lepidobatrachus*), a grouping that is strongly rejected by the molecular data sets and previous taxonomy (*Rana* and bufonids are also placed with this clade in parsimony and Bayesian morphological analyses, respectively).

Placement of hemiphractine hylids with other hylids in analyses of the morphology may be caused by the convergent acquisition of traits associated with arboreality

(e.g., offset terminal phalanges, character 73; claw-shaped terminal phalanges, character 74; intercalary phalangeal elements, character 77; modified base of metacarpal III, character 80), in contrast to the strong molecular evidence that hemiphractines are not closely related to other hylids. The placement of the clade Centrolenidae + *Allophryne* with hylids may also reflect the misleading effects of this suite of traits, although the specific placement of this clade by the molecular data is uncertain. Similarly, the basal placement of *Pseudis*, *Lysapsus*, *Acris*, and some *Pseudacris* within hylids in the morphological analyses may be associated with a reversion to terrestrial and/or aquatic lifestyle in these clades, with a concomitant loss of one or more of the characters associated with arboreality (e.g., offset terminal phalanges, expanded toe pads). The loss of these traits in the terrestrial/fossorial hylid *Cyclorana* (i.e., terminal phalanges not offset, not claw-shaped, loss of intercalary elements, toe pads not expanded) may also contribute to the erroneous placement of this taxon outside of Hylidae. In fact, *Cyclorana* was formerly classified with myobatrachids rather than other hylids (e.g., Lynch, 1971).

Despite the problems that these sets of characters have created in the morphological analyses, it would be difficult to argue that they are entirely misleading or that the characters are simply "bad." These problematic suites of characters help diagnose smaller clades that are also supported by the molecular data, such as the 30-chromosome "*Hyla*" (like microhylids and pipids, many species lack upper and lower labial tooth rows), highly ossified ceratophryne leptodactylids, and each of the three largely arboreal clades (Hemiphractinae, non-hemiphractine hylids, *Allophryne* + centrolenids). These characters can potentially contribute useful phylogenetic information, but clades supported primarily by these characters (e.g., Mendelson et al., 2000) should be viewed with appropriate caution. Furthermore, it might be an oversimplification to say that hylid morphology is problematic only because of homoplastic characters. The problem also may be a dearth of true phylogenetic signal. As potential evidence of this lack of true signal, there are only a handful of clades that are strongly supported by parsimony and Bayesian analyses of the morphological data. The combination of too little true signal with some misleading signal may be particularly prone to produce misleading phylogenetic results (e.g., Wiens et al., 2003).

Finally we note that these misleading signals are problematic in both parsimony and Bayesian analyses. Although some readers may be surprised by the failure of the model-based method for morphology (see also Wiens et al., 2005), it does make intuitive sense. Both parsimony and Bayesian methods assume that characters evolve independently of each other. If this assumption is violated, then both methods may be expected to fail in some cases.

Hylid Phylogeny and Taxonomy

The results of this study show that current hylid taxonomy reflects phylogeny very poorly. Although there are some uncertainties in our understanding of hylid phy-

logeny, there are many taxonomic changes that are necessary (in order to have the classification be consistent with the phylogeny) and strongly supported by our results. We take the estimates from our Bayesian and parsimony analyses of the combined data (including all taxa) as a starting point for our taxonomic changes. We acknowledge that some of these taxonomic issues could be considered an artifact of Linnean ranking, but it is clear that the Linnean ranks of "family" and "genus" remain widely used, and we prefer that these widely used taxon names (and ranks) be modified to reflect our understanding of phylogeny.

Hylids do not appear to be monophyletic. Specifically, hemiphractine hylids are grouped with eleutherodactyline leptodactylids (*Eleutherodactylus*, *Ischnocnema*, *Phrynopus*) in analyses of the combined molecular data and the combined molecular and morphological data sets. The sole exception is in the Bayesian analysis of the combined morphological and molecular data with 81 taxa only, in which hemiphractines are the sister group to a clade consisting of all other hylids, centrolenids, and allophrynids. There are no analyses of the molecular or combined data in which hemiphractines are grouped exclusively with hylids. However, hemiphractines are grouped with other hylids in analyses of the morphological data alone. We think that the hemiphractines are closely related to the eleutherodactyline leptodactylids, and that the placement of hemiphractines with other hylids in morphological analyses (and some combined Bayesian analyses) occurs because they share a suite of morphological traits associated with an arboreal ecomorph. We favor the molecular placement of hemiphractines given that both nuclear and mitochondrial genes support this placement, and that the morphological characters may represent shared adaptations to arboreal habitats and thus may not be fully independent (many of these traits seem to evolve concordantly in arboreal ranoids as well, such as rhacophorids and hyperoliids; Duellman and Trueb, 1986). However, the molecular evidence is somewhat complicated in that many of the separate analyses of the molecular data fail to cluster hemiphractines as a monophyletic group, possibly because of high levels of molecular divergence in these taxa. We recommend recognizing hemiphractines as a separate family (Hemiphractidae). Another possibility would be to assign Hemiphractinae to Leptodactylidae rather than recognizing it as a separate family. Unfortunately, Leptodactylidae is already a grossly polyphyletic family that must clearly be dismantled. We prefer to recognize a new family rather than assign hemiphractines to a demonstrably nonmonophyletic taxon. Given that hemiphractids are placed adjacent to some leptodactylids, many morphological synapomorphies (convergent with hylids) support the monophyly of the group, including intercalary elements and offset terminal phalanges.

Our data confirm the hypothesis that the former family or subfamily Pseudidae (*Pseudis* + *Lysapsus*) is nested inside of hylid hylids as the sister group to the genus *Scarthyla* (da Silva, 1998; Darst and Cannatella, 2004).

Thus, we recognize a monophyletic family Hylidae with three monophyletic subfamilies, Hylinae, Pelodyadinae, and Phyllomedusinae. All of these taxa (Hylidae, Hylinae, Pelodyadinae, Phyllomedusinae) are strongly supported by parsimony and Bayesian analyses of the combined and molecular data.

Our analyses show that the genus *Hyla* is polyphyletic, with almost all sampled species falling into three clades: (1) a clade of mostly large-bodied South American species, for which the genus name *Boana* Gray, 1825 is available; (2) the 30-chromosome clade of *Hyla*, for which *Dendropsophus* Fitzinger, 1843 is available; and (3) the Middle American clade, which contains the endemic hylinae genera of North and Middle America, in addition to most species of "*Hyla*" endemic to Middle America, North America, Europe, and Asia. Admittedly, the relationships among these three clades are not perfectly understood, but there are no analyses in which any of them are grouped together to the exclusion of other hylid genera. Many analyses support *Boana* as basal within hylines, place the 30-chromosome clade (*Dendropsophus*) with the *Pseudis* clade, and position the *Phrynohyas* clade as the sister group of the Middle American clade. Even if these three clades of "*Hyla*" did form a monophyletic group, continued recognition of "*Hyla*" as currently constituted would be problematic, given the placement of many other hylinae genera within the Middle American clade. Thus, we favor the dismantling of "*Hyla*." Although some might consider this dismantling premature given that we have included only 24.1% of the species of *Hyla*, we have included representatives of most species groups previously recognized within the genus (34 of 40).

Two of the taxonomic changes are obvious. First, following Duellman (2001), we recognize the genus *Boana* for the following species groups of "*Hyla*": *albomarginata*, *bogotensis*, *albopunctata*, *armata*, *boans*, *circumdata*, *geographica*, *granosa*, *larinopygion*, *polytaenia*, *pulchella*, and *punctata* (note that several groups were not originally assigned to this clade by Duellman [2001], including the *armata*, *bogotensis*, *circumdata*, *larinopygion*, and *polytaenia* groups). Second, we recognize *Dendropsophus* for the 30-chromosome clade of "*Hyla*," again following Duellman (2001). *Dendropsophus* would include the species of the *columbiana*, *garaoensis*, *labialis*, *leucophyllata*, *marmorata*, *microcephala*, *minuta*, *nana*, *parviceps*, and *minima* species groups of "*Hyla*" (but note that the *nana* and *minima* groups were not assigned to this clade by Duellman [2001]). Our assignment of species to these clades using these species groups should not be taken as a sign of confidence in the monophyly of the species groups. We merely assume that if one species in a species group is assigned to a given higher-level clade based on our analyses, then other species in that group will likely belong to that higher-level clade as well (as opposed to another, distantly related clade), especially given that there are morphological characters that differentiate these clades. Our results strongly support this assumption; although several species groups appear to be nonmonophyletic (e.g., *miotympanum* group), the members of a

species group always are placed in the same higher-level clade.

Taxonomic changes within the Middle American clade clearly are necessary, but are somewhat more complicated, as species of "*Hyla*" are interdigitated among several other genera in this part of the tree. The classification requiring the fewest overall taxonomic changes would place most Middle American genera into the synonymy of *Hyla* (sensu stricto), including *Anotheca*, *Duellmanohyla*, *Plectrohyla*, *Pternohyla*, *Ptychohyla*, *Smilisca*, and *Tripriion* (49 species total). This leaves all of the >100 species of *Hyla* in the Middle American clade as *Hyla*, including the type species of the genus (*Hyla arborea*) and many common and intensively studied species in North America, Europe, and Middle America. Furthermore, many of the currently recognized Middle American genera may be non-monophyletic (e.g., *Duellmanohyla*, *Ptychohyla*, *Smilisca*) or else contain only one or two species (*Anotheca*, *Pternohyla*, *Tripriion*). However, we favor continued recognition of *Acris* and *Pseudacris* as distinct genera, given their monophyly and seemingly basal position within the Middle American clade.

Such a dramatic change in the taxonomy of Middle American hylids may seem premature, given that our taxon sampling is limited and that some clades are only weakly supported. However, we have included 12 of the 13 species groups of *Hyla* that are likely to belong to the Middle American clade based on their geographic location, and all of the North and Middle American genera. Furthermore, most of the endemic genera of Middle American hylines are placed in well-supported clades with various species of *Hyla* (e.g., *Plectrohyla* with species of the *Hyla bistincta*, *sumichrasti*, and *melanoma* groups; *Ptychohyla* and *Duellmanohyla* with species of the *Hyla bromeliacia*, *miliaria*, and *miotympanum* groups; and the clade of *Anotheca*, *Pternohyla*, *Smilisca*, and *Tripriion* with species of the *Hyla arborea*, *godmani*, *pictipes*, *pseudopuma*, and *versicolor* groups; see Figs. 4 and 7). Thus, including more species could not make *Hyla* less nonmonophyletic, and the critical clades that support polyphyly of *Hyla* are strongly supported. Alternately, the nonmonophyly of *Hyla* could be corrected by expanding many of the Middle American genera to include more species of *Hyla*. However, this would likely require many more taxonomic changes than expanding *Hyla*, would radically alter the meanings of these generic names, and would be much more dependent on having a well-supported comprehensive phylogeny for the Middle American clade (conversely, lumping these genera into *Hyla* requires only minimal knowledge about the phylogeny within the clade).

Apart from the partitioning of *Hyla*, several other generic-level changes within Hylidae seem necessary based on our results. Within the *Phrynohyas* clade, we find that recognition of the monotypic West Indian genus *Calypthahyla* renders *Osteopilus* paraphyletic. Similarly, recognition of *Hyla pulchilineata* as a *Hyla* renders both *Osteopilus* and *Hyla* paraphyletic. Therefore, we favor placing *Calypthahyla* Trueb and Tyler 1974 and *Hyla pulchilineata* in the synonymy of *Osteopilus* Fitzinger, 1834.

Some authorities (e.g., Hedges, 1996; Hass et al., 2001; Powell and Henderson, 2003) have already placed *Calyptahyla*, *H. pulchilineata*, and other West Indian *Hyla* species (*H. marianae*, *H. vasta*, *H. wilderi*, but not *H. heilpreni*) into *Osteopilus*. We tentatively follow this decision based on our results that include *Osteopilus* (*Calyptahyla crucialis* and *O. (Hyla) pulchilineatus*).

Within phyllomedusines, *Phyllomedusa lemur* (a species of the *P. buckleyi* group) is placed with *Pachymedusa* and species of *Agalychnis* rather than with other species of *Phyllomedusa*, rendering *Phyllomedusa* paraphyletic. Duellman (1968) and Cannatella (1980) have previously suggested that members of the *P. buckleyi* species group might not be allied with other *Phyllomedusa*. Furthermore, we find little evidence that the monotypic genus *Pachymedusa* is phylogenetically distinct from species of *Agalychnis*. We therefore favor expanding the genus *Agalychnis* Cope 1864 to include species of the *P. buckleyi* species group and the genus *Pachymedusa* (Duellman, 1968). In theory, we could have instead erected a new genus for the *P. buckleyi* species group, but our results do not strongly rule out the possibility that such a genus is nested within *Agalychnis* (as traditionally recognized).

Within pelodyadines, our results support monophyly of *Nyctimystes* and *Cyclorana* but show paraphyly of *Litoria* with respect to these genera. However, our sampling of species within pelodyadines is too weak to support any taxonomic changes at this point in time.

We present a new proposed classification of hyliid frogs in online Appendix 5 (www.systematicbiology.org). We acknowledge that we have not yet included several genera of hyliid frogs, most of which are monotypic. Based on their morphological similarity to some members of the *Phrynohyas* clade, we suspect that many of these unsampled hyline genera will be added to this clade.

ACKNOWLEDGMENTS

Many of the tissue samples used in this study were originally obtained by William E. Duellman and J.J.W. in South America in the 1980s and 1990s, and we thank our field companions on those trips, including Luis A. Coloma, Fernando Cuadros Villanueva, David A. Kizirian, Joseph R. Mendelson, Michael E. Morrison, and Erik R. Wild. We are very grateful to the many individuals and institutions that kindly provided additional tissue samples, including Jonathan A. Campbell and Eric N. Smith (University of Texas at Arlington), Luis A. Coloma (Museo de Zoología, Pontificia Universidad Católica del Ecuador), Donna Ditman (Museum of Natural Science, Louisiana State University), Ignacio de la Riva, Maureen A. Donnelly, Robert E. Espinoza, José Grau, Eli Greenbaum, S. Blair Hedges, W. Ronald Heyer (United States National Museum), Karen R. Lips (Southern Illinois University at Carbondale), Brice P. Noonan, David Scheltinga, the late Joseph Slowinski (California Academy of Sciences), David B. Wake (Museum of Vertebrate Zoology, University of California at Berkeley), and Erik R. Wild. Patrick Stephens and Sarah Smith are gratefully acknowledged for their timely assistance with sequencing in the latter stages of the project. Adrian Nieto Montes de Oca assisted T.W.R. and J.J.W. with fieldwork in Mexico in 2002. Andrew Crawford kindly provided us with his *c-myc* primers prior to publication. J.J.W. thanks Kevin de Queiroz and Linda Trueb for provision of working space and other courtesies during collection work at the U.S. National Museum and University of Kansas Museum of Natural History. Rafe Brown, Todd Castoe, W. E. Duellman, Karl Kjer, Dan Moen, Rod Page, Jennifer Pramuk, Sarah Smith, and Patrick Stephens provided many

helpful comments on the manuscript. For financial support we thank the Carnegie Museum of Natural History and grants from the U.S. National Science Foundation (DEB-0129142, DEB-0331747, and DEB-0334923 to J.J.W.; DEB-9707428 and DEB-0108484 to T.W.R.).

REFERENCES

- Alfaro, M. E., S. Zoller, and F. Lutzoni. 2003. Bayes or bootstrap? A simulation study comparing the performance of Bayesian Markov chain Monte Carlo sampling and bootstrapping in assessing phylogenetic confidence. *Mol. Biol. Evol.* 20:255–266.
- AmphibiaWeb: Information on amphibian biology and conservation. [web application]. 2004. Berkeley, California: AmphibiaWeb. Available: <http://amphibiaweb.org/> (Accessed: August 30, 2004).
- Biju, S. D., and F. Bossuyt. 2003. New frog family from India reveals an ancient biogeographical link with the Seychelles. *Nature* 425:711–714.
- Brandley, M. C., A. Schmitz, and T. W. Reeder. 2005. Partitioned Bayesian analyses, partition choice, and the phylogenetic relationships of scincid lizards. *Syst. Biol.* 54:373–390.
- Cannatella, D. C. 1980. A review of the *Phyllomedusa buckleyi* group (Anura: Hylidae). *Occ. Pap. Mus. Nat. Hist. Univ. Kansas* 87:1–40.
- Chek, A. A., S. C. Loughheed, J. P. Bogart, and P. T. Boag. 2001. Perception and history: Molecular phylogeny of a diverse group of Neotropical frogs, the 30-chromosome *Hyla* (Anura: Hylidae). *Mol. Phylogenet. Evol.* 18:370–385.
- Crawford, A. J. 2003. Huge populations and old species of Costa Rican and Panamanian dirt frogs inferred from mitochondrial and nuclear gene sequences. *Mol. Ecol.* 12:2525–2540.
- Darst, C. R., and D. C. Cannatella. 2004. Novel relationships among hyliid frogs inferred from 12S and 16S mitochondrial DNA sequences. *Mol. Phylogenet. Evol.* 31:462–475.
- da Silva, H. R. 1997. Two character states new for hylines and the taxonomy of the genus *Pseudacris*. *J. Herpetol.* 31:609–613.
- da Silva, H. R. 1998. Phylogenetic relationships of the family Hylidae with emphasis on the relationships within the subfamily Hylinae (Amphibia: Anura). Ph.D. Dissertation, University of Kansas.
- De Queiroz, A. 1993. For consensus (sometimes). *Syst. Biol.* 42:368–372.
- Dingerkus, G., and L. D. Uhler. 1977. Enzyme clearing of alcian blue stained whole small vertebrates for demonstration of cartilage. *Stain Technol.* 52:229–232.
- Driskell, A. C., C. Ané, J. G. Burleigh, M. M. McMahon, B. C. O'Meara, and M. J. Sanderson. 2004. Prospects for building the Tree of Life from large sequence databases. *Science* 306:1172–1174.
- Duellman, W. E. 1968. The genera of phyllomedusine frogs (Anura: Hylidae). *Occ. Pap. Mus. Nat. Hist. Univ. Kansas* 18:1–10.
- Duellman, W. E. 1970. Hyliid frogs of Middle America, 1st edition. University of Kansas.
- Duellman, W. E. 1975. On the classification of frogs. *Occ. Pap. Mus. Nat. Hist. Univ. Kansas* 42:1–15.
- Duellman, W. E. 2001. Hyliid frogs of Middle America, 2nd edition. Society for the Study of Amphibians and Reptiles.
- Duellman, W. E., and L. Trueb. 1983. Frogs of the *Hyla columbiana* group: Taxonomy and phylogenetic relationships. Pages 33–51 in *Recent advances in herpetology and evolutionary biology* (A. G. J. Rhodin and K. Miyata, eds.). Museum of Comparative Zoology, Harvard University, Cambridge, Massachusetts.
- Duellman, W. E., and L. Trueb. 1986. *Biology of amphibians*. McGraw-Hill, New York.
- Duellman, W. E., and J. J. Wiens. 1992. The status of the hyliid frog genus *Olohygon* and the recognition of *Scinax* Wagler, 1830. *Occ. Pap. Mus. Nat. Hist. Univ. Kansas* 151:1–23.
- Dunon-Bluteau, D., and G. Brun. 1986. The secondary structures of the *Xenopus laevis* and human mitochondrial small ribosomal subunit RNA are similar. *FEBS Lett.* 198:333–338.
- Emerson, S. B., and P. A. Hastings. 1998. Morphological correlations in evolution: Consequences for phylogenetic analysis. *Quart. Rev. Biol.* 73:141–162.
- Erixon, P., B. Svennblad, T. Britton, and B. Oxelman. 2003. Reliability of Bayesian posterior probabilities and bootstrap frequencies in phylogenetics. *Syst. Biol.* 52:665–673.
- Faivovich, J., P. C. A. Garcia, F. Ananias, L. Lanari, N. G. Basso, and W. C. Wheeler. 2004. A molecular perspective on the phylogeny of the *Hyla pulchella* species group. *Mol. Phylogenet. Evol.* 32:938–950.

- Felsenstein, J. 1978. Cases in which parsimony or compatibility methods will be positively misleading. *Syst. Zool.* 27:401–410.
- Felsenstein, J. 1985. Confidence limits on phylogenies: An approach using the bootstrap. *Evolution* 39:783–791.
- Ford, L. S., and D. C. Cannatella. 1993. The major clades of frogs. *Herpetol. Monogr.* 6:94–117.
- Frost, D. R. 2001. *Amphibian Species of the World: An Online Reference*. Version 3.0 (22 August, 2004). Electronic database accessible at <http://research.amnh.org/herpetology/amphibia/index.html>. American Museum of Natural History, New York, USA.
- Gao, K., and M. A. Norell. 1998. Taxonomic revision of *Carusia* (Reptilia: Squamata) from the Late Cretaceous of the Gobi Desert and phylogenetic relationships of anguimorph lizard. *Am. Mus. Nov.* 3230:1–51.
- Gauthier, J. 1986. Saurischian monophyly and the origin of birds. *Mem. Calif. Acad. Sci.* 8:1–47.
- Goldman, N., J. P. Anderson, and A. G. Rodrigo. 2000. Likelihood-based tests of topologies in phylogenetics. *Syst. Biol.* 49:652–670.
- Graybeal, A. 1997. Phylogenetic relationships of bufonid frogs and tests of alternate macroevolutionary hypotheses characterizing their radiation. *Zool. J. Linn. Soc.* 119:297–338.
- Graybeal, A. 1998. Is it better to add taxa or characters to a difficult phylogenetic problem? *Syst. Biol.* 47:9–17.
- Gu, X., Y.-X. Fu, and W.-H. Li. 1995. Maximum likelihood estimation of the heterogeneity of substitution rate among nucleotide sites. *Mol. Biol. Evol.* 12:546–557.
- Hasegawa, M., H. Kishino, and T. Yano. 1985. Dating the human-ape split by a molecular clock of mitochondrial DNA. *J. Mol. Evol.* 22:160–174.
- Hass, C. A., L. R. Maxson, and S. B. Hedges. 2001. Relationships and divergence times of West Indian amphibians and reptiles: Insights from albumin immunology. Pages 157–174 in *Biogeography of the West Indies: Patterns and perspectives* (C. A. Woods and F. E. Sergile, eds.). CRC Press, Boca Raton, Florida.
- Hay, J. M., I. Ruvinsky, S. B. Hedges, and L. R. Maxson. 1995. Phylogenetic relationships of amphibian families inferred from DNA sequences of mitochondrial 12S and 16S ribosomal genes. *Mol. Biol. Evol.* 12:928–937.
- Hedges, S. B. 1996. The origin of West Indian amphibians and reptiles. Pages 95–128 in *Contributions to West Indian herpetology: A tribute to Albert Schwartz* (R. Powell and R. W. Henderson, eds.). Society for the Study of Amphibians and Reptiles, Contributions to Herpetology, vol. 12, Ithaca, New York.
- Hendy, M. D., and D. Penny. 1989. A framework for the quantitative study of evolutionary trees. *Syst. Zool.* 38:297–309.
- Hillis, D. M. 1996. Inferring complex phylogenies. *Nature* 383:130–131.
- Hillis, D. M. 1998. Taxonomic sampling, phylogenetic accuracy, and investigator bias. *Syst. Biol.* 47:3–8.
- Hillis, D. M., and J. J. Bull. 1993. An empirical test of bootstrapping as a method for assessing confidence in phylogenetic analysis. *Syst. Biol.* 42:182–192.
- Hillis, D. M., B. K. Mable, and C. Moritz. 1996. Applications of molecular systematics: The state of the field and a look to the future. Pages 515–543 in *Molecular systematics*, 2nd edition (D. M. Hillis, C. Moritz, and B. K. Mable, eds.). Sinauer Associates, Sunderland, Massachusetts.
- Hillis, D. M., D. D. Pollock, J. A. McGuire, and D. J. Zwickl. 2003. Is sparse taxon sampling a problem for phylogenetic inference? *Syst. Biol.* 52:124–126.
- Hoegg, S., M. Vences, H. Brinkmann, and A. Meyer. 2004. Phylogeny and comparative substitution rates of frogs inferred from sequences of three nuclear genes. *Mol. Biol. Evol.* 21:1188–1200.
- Huelsenbeck, J. P., D. M. Hillis, and R. Jones. 1996. Parametric bootstrapping in molecular phylogenetics: Applications and performance. Pages 19–45 in *Molecular zoology: Advances, strategies, and protocols* (J. D. Ferraris and S. R. Palumbi, eds.). Wiley-Liss, New York.
- Huelsenbeck, J. P., and B. Rannala. 2004. Frequentist properties of Bayesian posterior probabilities. *Syst. Biol.* 53:904–913.
- Huelsenbeck, J. P., and F. Ronquist. 2001. MrBayes: Bayesian inference of phylogeny. *Bioinformatics* 17:754–755.
- Jukes, T. H., and C. R. Cantor. 1969. Evolution of protein molecules. Pages 21–132 in *Mammalian protein metabolism* (H. Munro, ed.). Academic Press, New York.
- Kass, R. E., and A. E. Raftery. 1995. Bayes factors. *J. Am. Stat. Assoc.* 90:773–795.
- Kim, J. 1996. General inconsistency conditions for maximum parsimony: Effects of branch lengths and increasing numbers of taxa. *Syst. Biol.* 45:363–374.
- Kim, J. 1998. Large-scale phylogenies and measuring the effects of phylogenetic estimators. *Syst. Biol.* 47:43–60.
- Leviton, A. E., R. H. Gibbs, E. Heal, and C. E. Dawson. 1985. Standards in herpetology and ichthyology: Part 1. Standard symbolic codes for institutional resource collections in herpetology and ichthyology. *Copeia* 1985:802–832.
- Lewis, P. O. 2001. A likelihood approach to inferring phylogeny from discrete morphological characters. *Syst. Biol.* 50:913–925.
- Lynch, J. D. 1971. Evolutionary relationships, osteology, and zoogeography of leptodactylid frogs. *Misc. Publ. Mus. Nat. Hist. Univ. Kansas* 53:1–238.
- Lynch, J. D. 1973. The transition from archaic to advanced frogs. Pages 131–182 in *Evolutionary biology of the anurans* (J. L. Vial, ed.), University of Missouri Press, Columbia, Missouri.
- Lynch, J. D. 1978. A re-assessment of the telmatobiine leptodactylid frogs. *Occ. Pap. Mus. Nat. Hist. Univ. Kansas* 72:1–57.
- Macey, J. R., J. A. Schulte II, A. Larson, N. B. Ananjeva, Y. Wang, R. Pethiyagoda, N. Rastegar-Pouyani, and T. J. Papenfuss. 2000. Evaluating trans-Tethys migration: An example using acrodont lizard phylogenetics. *Syst. Biol.* 49:233–256.
- Mendelson, J. R. III, H. R. Da Silva, and A. M. Maglia. 2000. Phylogenetic relationships among marsupial frog genera (Anura: Hylidae: Hemiphraetinae) based on evidence from morphology and natural history. *Zool. J. Linn. Soc.* 128:125–148.
- Moriarty, E. C., and D. C. Cannatella. 2004. Phylogenetic relationships of the North American chorus frogs (*Pseudacris*: Hylidae). *Mol. Phylogenet. Evol.* 30:409–420.
- Murphy, W. J., E. Eizirik, W. J. Johnson, Y. P. Zhang, O. A. Ryder, and S. J. O'Brien. 2001. Molecular phylogenetics and the origins of placental mammals. *Nature* 409:614–618.
- Novacek, M. J. 1992. Fossils, topologies, missing data, and the higher level phylogeny of eutherian mammals. *Syst. Biol.* 41:58–73.
- Nylander, J. A. A. 2004. MrModeltest 2.0. Program distributed by the author. Evolutionary Biology Centre, Uppsala University. (<http://www.ebc.uu.se/systzoo/staff/nylander.html>).
- Nylander, J. A. A., F. Ronquist, J. P. Huelsenbeck, and J. L. Nieves-Aldrey. 2004. Bayesian phylogenetic analysis of combined data. *Syst. Biol.* 53:47–67.
- Phillips, H., E. A. Snell, E. Baptiste, P. Lopez, P. W. H. Holland, and D. Casane. 2004. Phylogenomics of eukaryotes: Impact of missing data on large alignments. *Mol. Biol. Evol.* 21:1740–1752.
- Poe, S. 1998. Sensitivity of phylogeny estimation to taxonomic sampling. *Syst. Biol.* 47:18–31.
- Poe, S., and D. L. Swofford. 1999. Taxon sampling revisited. *Nature* 398:299–300.
- Powell, R., and R. W. Henderson. 2003. A second set of addenda to the checklist of West Indian amphibians and reptiles. *Herp. Rev.* 34:341–345.
- Rannala, B., J. P. Huelsenbeck, Z. Yang, and R. Nielsen. 1998. Taxon sampling and the accuracy of large phylogenies. *Syst. Biol.* 47:702–710.
- Rodríguez, J., L. Oliver, A. Marín, and R. Medina. 1990. The general stochastic model of nucleotide substitution. *J. Theor. Biol.* 142:485–501.
- Roelants, K., and F. Bossuyt. 2005. Archaeobatrachian paralogy and pangaean diversification of crown-group frogs. *Syst. Biol.* 54:111–126.
- Rosenberg, M. S., and S. Kumar. 2001. Incomplete taxon sampling is not a problem for phylogenetic inference. *Proc. Natl. Acad. Sci. USA* 98:10751–10756.
- Rosenberg, M. S., and S. Kumar. 2003. Taxon sampling, bioinformatics, and phylogenomics. *Syst. Biol.* 52:119–124.
- Swofford, D. L. 2002. PAUP*: Phylogenetic analysis using parsimony*, version 4.0b10. Sinauer Associates, Sunderland, Massachusetts.
- Takezaki, N., F. Figueroa, Z. Zaleska-Rutczynska, and H. Takahata. 2004. The phylogenetic relationship of tetrapod, coelacanth, and

- lungfish revealed by the sequences of forty-four nuclear genes. *Mol. Biol. Evol.* 21:1512–1524.
- Templeton, A. R. 1983. Phylogenetic inference from restriction endonuclease cleavage site maps with particular reference to the evolution of humans and the apes. *Evolution* 37:221–244.
- Thompson, J. D., D. G. Higgins, and T. J. Gibson. 1994. CLUSTAL W: Improving the sensitivity of progressive multiple sequence alignment through sequence weighting, position specific gap penalties and weight matrix choice. *Nucleic Acids Res.* 22:4673–4680.
- Tyler, M. J. 1971. The phylogenetic significance of vocal sac structure in hylid frogs. *Univ. Kans. Publ. Mus. Nat. Hist.* 19:319–360.
- Wiens, J. J. 1998a. The accuracy of methods for coding and sampling higher-level taxa for phylogenetic analysis: A simulation study. *Syst. Biol.* 47:381–397.
- Wiens, J. J. 1998b. Does adding characters with missing data increase or decrease phylogenetic accuracy? *Syst. Biol.* 47:625–640.
- Wiens, J. J. 1998c. Combining data sets with different phylogenetic histories. *Syst. Biol.* 47:568–581.
- Wiens, J. J. 1999. Polymorphism in systematics and comparative biology. *Ann. Rev. Ecol. Syst.* 30:327–362.
- Wiens, J. J. 2001. Character analysis in morphological phylogenetics: Problems and solutions. *Syst. Biol.* 50:689–699.
- Wiens, J. J. 2003. Missing data, incomplete taxa, and phylogenetic accuracy. *Syst. Biol.* 52:528–538.
- Wiens, J. J., R. M. Bonett, and P. T. Chippindale. 2005. Ontogeny discombobulates phylogeny: paedomorphosis and higher-level salamander relationships. *Syst. Biol.* 54:91–110.
- Wiens, J. J., P. T. Chippindale, and D. M. Hillis. 2003. When are phylogenetic analyses misled by convergence? A case study in Texas cave salamanders. *Syst. Biol.* 52:501–514.
- Wiens, J. J., and T. W. Reeder. 1995. Combining data sets with different numbers of taxa for phylogenetic analysis. *Syst. Biol.* 44:548–558.
- Wiens, J. J., and T. W. Reeder. 1997. Phylogeny of the spiny lizards (*Sceloporus*) based on molecular and morphological evidence. *Herpetol. Monogr.* 11:1–101.
- Wilcox, T. P., D. J. Zwickl, T. A. Heath, and D. M. Hillis. 2002. Phylogenetic relationships of the dwarf boas and a comparison of Bayesian and bootstrap measures of phylogenetic support. *Mol. Phylogenet. Evol.* 25:361–371.
- Wilkinson, M., and M. J. Benton. 1995. Missing data and rhynchosaur phylogeny. *Hist. Biol.* 10:137–150.
- Yang, Z. 1993. Maximum likelihood estimation of phylogeny from DNA sequences when substitution rates differ over sites. *Mol. Biol. Evol.* 10:1396–1401.
- Yang, Z. 1994. Maximum likelihood phylogenetic estimation from DNA sequences with variable rates over sites: Approximate methods. *J. Mol. Evol.* 39:306–314.
- Zwickl, D. J., and D. M. Hillis. 2002. Increased taxon sampling greatly reduces phylogenetic error. *Syst. Biol.* 51:588–598.

First submitted 17 November 2004; reviews returned 8 March 2005;

final acceptance 19 May 2005

Associate Editor: Karl Kjer

APPENDIX

APPENDIX 1. MORPHOLOGICAL CHARACTER DESCRIPTIONS

Nonmolecular characters (morphological, life history, chromosomal) used in phylogenetic analyses. Citations emphasize the first usage of a character in an explicit phylogenetic analysis but do not indicate that the data were obtained from that source. Anatomical terminology generally follows Duellman and Trueb (1986). Designation of states as “0” is arbitrary and does not necessarily indicate polarity; rooting was determined by inclusion of outgroup taxa and not a priori polarity of character states. For ordered characters with more than 6 states, states greater than 5 were combined in the Bayesian analyses (states from 6 to 9 set equal to 5; only affected characters 121 and 144).

OSTEOLOGY

Cranial

1. Premaxillary and maxillary dentition: (0) absent, (1) present. Character from Lynch (1971).
2. Premaxilla, palatal shelf wide, with distinct median and lateral process: (0) absent, (1) present. Character from Lynch (1971).
3. Maxillary teeth: (0) pedicellate, (1) nonpedicellate. Character from Lynch (1971).
4. Pars palatina of maxilla (medially projecting process): (0) present, (1) absent.
5. Pars facialis of maxilla (dorsally projecting sheet): (0) present, (1) absent.
6. Median contact of nasals: (0) absent, (1) present. Character from Mendelson et al. (2000).
7. Nasal-frontoparietal articulation: (0) absent, (1) present. Character from Mendelson et al. (2000).
8. Nasal and frontoparietal completely cover sphenethmoid (0) no, (1) yes.
9. Nasal-maxilla articulation: (0) absent, (1) present. Character from Duellman (1970).
10. Nasal-squamosal contact: (0) absent, (1) present.
11. Cranial exostosis: (0) absent, (1) present. Character from Lynch (1971).
12. Frontoparietals: (0) parallel anteriorly, (1) strongly divergent anteriorly.
13. Supraorbital flange on frontoparietals, projecting into orbit: (0) absent, (1) present. Character from Mendelson et al. (2000).
14. Frontoparietal fontanelle: (0) absent, (1) present. Character from Duellman (1970).
15. Squamosal-frontoparietal contact: (0) absent, (1) present.
16. Canal for occipital artery in frontoparietal: (0) absent, (1) present. Character from Lynch (1971).
17. Quadratojugal: (0) absent, (1) present. Character from Duellman (1970).
18. Quadratojugal-maxilla articulation: (0) absent, (1) present. Character from Duellman (1970).
19. Zygomatic ramus of squamosal: (0) absent, (1) present.
20. Anterior end of zygomatic ramus of squamosal: (0) free, (1) articulates, with maxilla, (2) articulates with pterygoid. Unordered.
21. Zygomatic and otic rami squamosal: (0) oriented anteroposteriorly, (1) anterolaterally.
22. Zygomatic ramus of squamosal: (0) no sharp ventral deflection, (1) sharp ventral deflection.
23. Bony articulation between squamosal and crista parotica: (0) absent, (1) present. Character from Duellman (1970).
24. Vomer: (0) normal, with pre and postchoanal rami, (1) reduced, lacking rami.
25. Vomerine teeth: (0) absent, (1) present. Character from Duellman (1970).
26. Vomerine tooth rows: (0) transverse or short, (1) elongate, angular. Character modified from Duellman (1970).
27. Neopalatine: (0) absent, (1) present. Character modified from Lynch (1973).
28. Posterior ramus of pterygoid: (0) absent, (1) present.
29. Parasphenoid-ptyerygoid contact: (0) absent, (1) present.
30. Septum nasi: (0) cartilaginous, (1) partly or entirely ossified.
31. Sphenethmoid: (0) single, (1) divided. Discussed by Ford and Cannatella (1993).
32. Laterally projecting cartilaginous process in orbital region: (0) absent, (1) present.
33. Orbital cartilage: (0) absent or not elongate, (1) elongate.
34. Process (cartilaginous or ossified) extending from posterolateral corner of crista parotica: (0) absent, (1) present.
35. Tympanic annulus: (0) absent, (1) present.
36. Tympanic annulus: (0) separate from crista parotica, (1) fused to crista parotica.
37. Tympanic ring: (0) open, (1) closed.
38. Pars interna plectri: (0) short, rounded, (1) elongate, rodlike.
39. Pars interna plectra: (0) expanded ventrally, (1) not expanded.
40. Retroarticular process of mandible: (0) absent, (1) present. Character from Ford and Cannatella (1993).

41. Mandibular fangs: (0) absent, (1) present. Character from Duellman (1970).

Hyoid Morphology

42. Anterior process on the hyale: (0) absent, (1) present. Character from Lynch (1971).
 43. Anterolateral process of hyoid plate: (0) present, (1) absent. Character from Lynch (1971).
 44. Anterolateral (alary) hyoid process: (0) base narrow, (1) base broad, winglike. Character from Lynch (1971).
 45. Hyoid plate: (0) wider than long, (1) longer than wide.
 46. Posterolateral process of hyoid plate: (0) present, (1) absent.
 47. Posterolateral hyoid processes: (0) not extending posterior to posterior edge of hyoid plate, (1) extending posterior to posterior edge of hyoid plate.
 48. Posteromedial hyoid process: (0) oriented posteriorly, (1) curved dorsally.
 49. Median contact of ossification of posteromedial hyoid processes on hyoid plate: (0) separate, (1) abutting but not fused, (2) fused. Ordered.

Vertebral Morphology

50. Vertebrae I and II: (0) separate, (1) fused. Character from Lynch (1973).
 51. Number of presacral vertebrae: (0) 8, (1) 7, (2) 6. Ordered. Character modified from Lynch (1973).
 52. Vertebrae: (0) procoelous, (1) diplasiocoelous, (2) notochordal. Unordered. Character modified from Lynch (1971).
 53. Vertebral shield: (0) absent, (1) present. Character from Lynch (1971).
 54. Transverse process of presacral vertebra IV: (0) normal, (1) elongate. Character from Duellman and Wiens (1992), in reference to *Sphaenorhynchus*.
 55. Posteriormost presacral vertebra, transverse processes: (0) anteriorly oriented, (1) lateral.
 56. Posterior most four presacral vertebrae: (0) nonimbricate, (1) imbricate (no space visible between neural arches dorsally). Character modified from Lynch (1973).
 57. Sacral diapophyses: (0) expanded laterally, (1) cylindrical, not expanded laterally. Character modified from Lynch (1971).
 58. Sacral diapophyses, bony portion: (0) flat in lateral view, (1) rounded, dilated dorsally. Character modified from Lynch (1971).
 59. Sacral diapophyses, with cartilaginous lateral margins extending well beyond bony margins: (0) absent, (1) present.
 60. Sacro-coccygeal articulation: (0) bicondylar, (1) monocondylar, (2) fused. Unordered. Character modified from Lynch (1973).
 61. Coccygeal flange (lateral projection on anterior portion of coccyx): (0) absent, (1) present. Character modified from Lynch (1973).
 62. Coccygeal crest (dorsal projection on anterior portion of coccyx): (0) absent, (1) present.

Pectoral Girdle

63. Omosternum: (0) absent, (1) present.
 64. Ossified style of omosternum: (0) absent, (1) present.
 65. Omosternum: (0) not elongate, shorter than length of sternum, (1) elongate, length greater than or equal to sternum length.
 66. Fusion of epicoracoid cartilages: (0) absent, cartilages overlap, (1) cartilages abutting or partially fused, (2) cartilages fused. Ordered. Character modified from Ford and Cannatella (1993).
 67. Sternum: (0) normal, (1) reduced, half of the maximum antero-posterior length of the epicoracoid cartilages or smaller.
 68. Ossified sternal style: (0) absent, (1) present. Character from Lynch (1971).
 69. Posterior margin of sternum, distinct median notch: (0) absent, (1) present.
 70. Medial end of coracoid: (0) equal to or narrower than lateral end (1) wider than lateral end. Character from Ford and Cannatella (1993).
 71. Suprascapula (cleithrum): (0) with anterior and posterior dorsal bony processes, (1) anterior process only.

72. Suprascapula, anteromedial process (projects beyond cleithrum): (0) absent, (1) present.

Forelimb Morphology

73. Terminal phalange offset ventrally: (0) no, terminal phalanges in single plane, (1) yes. Character from Duellman (2001).
 74. Shape of terminal phalange: (0) rounded, (1) claw-shaped, (2) T-shaped, with lateral processes. Unordered. Character from Duellman (2001).
 75. Distinct cartilaginous ventral process near base of terminal phalanges of fingers: (0) absent, (1) present. Character from Duellman (2001).
 76. Paired lateral processes on distal ventral surface of penultimate phalanges: (0) absent, (1) present.
 77. Intercalary elements: (0) absent, (1) present. Character modified from Duellman and Trueb (1986).
 78. Intercalary elements: (0) not ossified, (1) ossified. Character modified from Duellman (2001).
 79. Finger II length: (0) longer than or equal to finger I, (1) shorter than finger I. Character modified from Duellman (1970).
 80. Base of metacarpal III: (0) does not articulate with other metacarpals, (1) articulates with IV, (2) II and IV. Ordered.
 81. Width of base of metacarpal II: (0) similar to metacarpal III; (1) wider than III.
 82. Cartilaginous bump near mid-length on metacarpal III: (0) absent, (1) present.
 83. Sesamoid elements at distal end of metacarpals: (0) absent, (1) present.
 84. Palmar sesamoid element: (0) absent, (1) present.
 85. Fusion of third distal carpal to others: (0) absent, (1) present.
 86. Prepollex: (0) normal, (1) greatly reduced to few small carpal elements.
 87. Prepollex: (0) lateral to metacarpal I, (1) ventral to metacarpal I.
 88. Expanded articular surface of metacarpal V: (0) does not extend onto dorsal surface of metacarpal V, (1) extends onto dorsal surface.
 89. Number of distal prepollical elements (not contacting carpal I): (0) one or more, (1) none.
 90. Prepollex, (0) rounded, not bladelikey, (1) bladelikey, laterally compressed and projecting ventrally.
 91. Prepollex, second element (next to most proximal) contacts metacarpal I: (0) no, (1) yes.
 92. Humeral spine in males: (0) absent, (1) present.

Pelvic Girdle

93. Iliac crest: (0) absent, (1) present. Character from Lynch (1971).

Hindlimb Morphology

94. Proximal heads of metatarsals IV and V: (0) separate, (1) fused. Character from da Silva (1997).
 95. Bony bump or process on proximal, prehallal surface of metatarsal III: (0) absent, (1) present.
 96. Element on posterior surface of prehallux: (0) absent, (1) present.
 97. Fibulare and tibiale: (0) fused only proximally and distally, (1) fused throughout their lengths. Character from Duellman and Trueb (1986).

EXTERNAL MORPHOLOGY

98. Expanded toe pads: (0) absent, (1) present.
 99. Webbing on hands: (0) absent, (1) present.
 100. Keratinized nuptial excrescence in males: (0) absent, (1) present.
 101. Enlarged prepollical spine: (0) absent, (1) present. Character from Duellman (1970).
 102. Webbing on toes: (0) absent, (1) present but partial, (2) toes fully webbed. Ordered.
 103. Inner metatarsal tubercle (0) not enlarged and shovel-like, (1) enlarged and shovel-like.
 104. Outer metatarsal tubercle: (0) absent, (1) present. Character from Lynch (1973).

105. Calcar on heel: (0) absent, (1) present. Character from Duellman (1970).
106. Pupil shape (0) horizontal, (1) vertical. Character from Lynch (1971).
107. Palpebral membrane: (0) not pigmented, (1) pigmented. Character modified from Duellman (1970).
108. Tympanum: (0) exposed, (1) hidden. Character modified from Duellman (1970).
109. Paratoid gland: (0) absent, (1) present. Taken from Lynch (1971).
110. Spicules on dorsum: (0) absent, (1) present.
111. Cornified spicules (spines) visible in epidermis: (0) absent, (1) present.
112. Belly texture: (0) smooth, (1) granular.
113. Vocal sac: (0) present, (1) absent. Character modified from Duellman (1970).
114. Vocal sac: (0) single, (1) paired. Character modified from Duellman (1970).
115. Vocal sac: (0) subgular, (1) lateral. Character modified from Duellman (1970).
116. Throat (vocal sac) coloration in males: (0) same color as rest of venter, (1) darker than rest of venter, (2) throat and venter darkly colored. Unordered. Taxa with lateral vocal sacs were coded as unknown.

TADPOLE MORPHOLOGY

117. Spiracle, (0) lateral, (1) ventrolateral. Character from Duellman (2001).
118. Mouth (0) not funnel-shaped, (1) funnel-shaped. Character from Duellman (1970).
119. Oral disc: (0) oriented anteroventrally, (1) ventrally. Character modified from Duellman (1970).
120. Beak (jaw sheath): (0) upper and lower present, (1) upper beak absent, (2) both beaks absent. Ordered.
121. Labial tooth rows: upper: 0–8 (ordered meristic character). Ordered. Character modified from Duellman (1970).
122. Labial tooth rows: lower: 0–9 (ordered meristic character). Ordered. Character modified from Duellman (1970).
123. Gap in upper labial tooth row: (0) absent, (1) present.
124. Gap in first lower labial tooth row: (0) absent, (1) present.
125. Gap in lowermost labial tooth row: (0) absent, (1) present.
126. Marginal labial tooth rows (0) continuous, (1) discontinuous (multiple gaps).
127. Labial arm supporting lower tooth row: (0) absent, (1) present.
128. Lateral labial folds (0) absent, (1) present.
129. Lateral fold in labial papillae: (0) absent, (1) present.
130. Gap in marginal papillae on upper labium (0) present, (1) absent. Character modified from Duellman (1970).
131. Ventral labial papilla: (0) absent, (1) present. Character modified from Duellman (1970).
132. Ventral marginal papilla: (0) 1 row, (1) 2 rows, (2) multiple rows. Ordered.
133. Lateral marginal papilla: (0) 1 row, (1) 2 rows, (2) multiple rows. Ordered.
134. Lateral inframarginal papilla (0) absent, (1) present.
135. Lateral marginal papilla continuous with inframarginal papilla (0) no, (1) yes.
136. Embryonic gills: (0) small, slender; (1) large, bell-shaped. Data and character summarized in Duellman (2001).

MUSCLE CHARACTERS

137. Supplementary intermandibularis muscle: (0) absent, (1) present. Character modified from Duellman (2001), data from Tyler (1971).
138. Position of supplementary intermandibularis muscle: (0) apical, (1) anterolateral, (2) posterolateral. Unordered. Character modified from Duellman (2001), data from Tyler (1971).

LIFE HISTORY

139. Egg deposition: (0) in water, (1) over water, (2) female dorsum (male in *Colostethus*), (3) on land. Unordered. Data from summaries in Lynch (1971), Duellman and Trueb (1986), and Duellman (2001).
140. Aquatic egg deposition: (0) still or slow moving water, (1) stream, (2) tree-hole cavity, (3) bromeliad. Unordered. Data from summaries in Lynch (1971), Duellman and Trueb (1986), and Duellman (2001).
141. Pouch for eggs: (0) absent, (1) present. Data from Mendelson et al. (2000) and our observations.
142. Direct development: (0) absent, (1) present. Data from summaries in Lynch (1971), Duellman and Trueb (1986), Duellman (2001), and Mendelson et al. (2000).
143. Construction of a foam nest for eggs: (0) absent, (1) present. Data from summaries in Lynch (1971), Duellman and Trueb (1986), and Duellman (2001).

CHROMOSOMAL

144. Diploid chromosome number: (0) 20, (1) 22, (2) 24, (3) 26, (4) 28, (5) 30, (6) 32, (7) 34, (8) 36. Ordered. Data summarized by Duellman and Trueb (1986).

AUTHORS' NOTE

We note two developments that occurred subsequent to our paper going to press. First, we discovered some minor errors in our analyses. These involved: (a) errors involving a few base pairs each for the POMC and *c-myc* genes in eight taxa, (b) an incorrect chromosome number in one taxon (*Hyla nana*), and (c) failure to unlink one of the parameters (proportion of invariant sites) across partitions in the Bayesian analyses. The relevant phylogenetic analyses were rerun after correcting these mistakes, and the resulting trees and levels of branch support are nearly identical to those reported in the paper. The only differences involve clades that have relatively weak support. These trees are available on the web-site of the senior author.

Second, an extensive molecular analysis of hylid relationships appeared recently in a museum publication (Faivovich, J., C. F. B. Haddad, P. C. A. Garcia, D. R. Frost, J. A. Campbell, and W. C. Wheeler. 2005. Systematic review of the frog family Hylidae, with special reference to Hylinae: phylogenetic analysis and taxonomic revision. *Bull. Am. Mus. Nat. Hist.* 294:1–240). The study was based on equally weighted parsimony analysis of many of the same taxa (as well as many additional taxa) based on data from up to four mitochondrial and five nuclear genes per taxon (including one overlapping mitochondrial gene, 12S). The study by Faivovich et al. (2005; FEA hereafter) supports the major clades found in our analysis, and is consistent with most of the species-level relationships as well. Most importantly, for all of the taxa that were incomplete in our study and that were also included by FEA, the placement of each incomplete taxon in a major clade in our study was corroborated by additional data in the analysis of FEA. Thus, the analysis of FEA seems to support the major conceptual conclusion of our study: that incomplete taxa can be accurately placed in phylogenetic analyses that combine the top-down and bottom-up sampling approaches.

The FEA study also made several changes in the taxonomy of hylid frogs beyond those made in our study. We agree with many of these changes (e.g., further partitioning and renaming of the *Boana* clade) whereas others seem unnecessary but nevertheless consistent with our results (e.g., many new genera within the Middle American clade). An analysis combining our data with that of FEA is presently underway, and our suggested taxonomy will be published in a subsequent paper.